

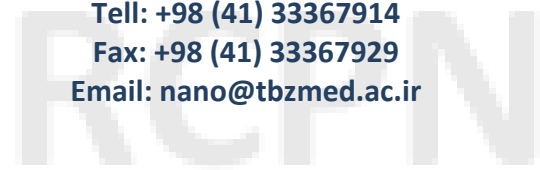

**LABORATORY
BIOSAFETY
Manual**



Research Center for Pharmaceutical Nanotechnology, University Avenue, Tabriz, Iran
URL: nano.tbzmed.ac.ir
Tell: +98 (41) 33367914
Fax: +98 (41) 33367929
Email: nano@tbzmed.ac.ir



Foreword

With no doubt all experimenters who deal with chemicals, toxins, biologics, microorganisms and human samples must be aware of safety issues prior to conducting any experiment. All the researchers of RCPN must have the necessary information and knowledge upon safety incidences. As a matter of fact, any laboratory work requires the knowledge of the experiment and necessary trainings, in addition to general skills and trainings. At RCPN, we follow the safety codes which are required to be taken into consideration during the laboratory works. We need to understand the impact of each hazardous agent prior to handling it to take proper precautions for better protection at all times during the experiment. All the members of RCPN are required to comply with the highest standard possible to make sure upon the quality and the integrity of the researches carried out.

The main objective of this training manual is to provide a brief overview and insight upon the lab safety requirements in order to prevent accidents, injuries, and illness during the job/experiment.

Sincerely,

Dr Y. Omid
Director of RCPN

RCPN

Lab Safety A to Z

Contents

Foreword.....	II
The Culture of Laboratory Safety	8
ABBREVIATIONS AND ACRONYMS	9
GLOSSARY	11
General Principles.....	14
WHO Classification of Infective Microorganisms by Risk Group (2004).....	17
Accident/Injury Reports	17
Animal Facilities.....	18
Animal Facility – Biosafety Level 1	18
Animal Facility – Biosafety Level 2.....	19
Animal Facility – Biosafety Level 3.....	19
Animal Facility – Biosafety Level 4.....	20
Appropriate Clothing in Laboratories.....	21
Biological Hazard Operations.....	23
Biological Safety Work Practices.....	24
Biological Safety Cabinets	26
Class I Biological Safety Cabinet.....	27
Class II Biological Safety Cabinets	27
Class II Type A1 Biological Safety Cabinet.....	28
Class III Biological Safety Cabinet.....	30
Biological Safety Cabinet Air Connections	30
Selection of a Biological Safety Cabinet.....	31
Using Biological Safety Cabinets in the Laboratory Location.....	31
Operators	31
Material Placement.....	31
Operation and Maintenance.....	32
Ultraviolet Lights.....	32
Open Flames	32

Spills	32
Certification.....	32
Cleaning and Disinfection	33
Decontamination	33
Personal Protective Equipment	33
Alarms	33
Supplementary Information	34
Biohazard Warning Sign	34
Care and Use of Refrigerators and Freezers.....	34
Centrifuge and Rotor Safety Guide	35
Emergency Equipment	37
Chemical Hazard Operations	38
Chemical Hygiene Plan	40
Ordering Chemicals.....	41
Chemical Procurement	41
Chemical Storage	42
Chemical Inventory	43
Chemical Waste	44
Chemical Spill Policy.....	44
Low-Flammability and Low-Toxicity Materials that are not Volatile.....	44
Flammable Solvents of Low Toxicity	44
Highly Toxic Materials.....	45
Closing the Door on Lab Safety Hazards	45
Disposal of Chemical Waste.....	46
Disinfection and Sterilization.....	46
Definitions.....	47
Cleaning Laboratory Materials.....	47
Chemical Germicides.....	47
Chlorine (sodium hypochlorite)	48
Sodium dichloroisocyanurate	49
Chloramines	49
Chlorine dioxide	50

Formaldehyde	50
Glutaraldehyde	50
Phenolic compounds.....	51
Quaternary ammonium Compounds	51
Alcohols.....	51
Iodine and Iodophors.....	52
Hydrogen peroxide and Peroxides	52
Local Environmental Decontamination	53
Decontamination of Biological Safety Cabinets.....	53
Disposal of Biological Waste.....	54
Disposal of Chemical Waste.....	54
Electrical and Mechanical Safety	55
Compressed Gases	55
General Standards.....	55
Flammable gases: Special care must be used when gases are used in confined spaces	56
Pressure regulators and needle valves	56
Leak Testing	56
Empty Cylinders	57
Ultraviolet Light Decontamination	57
UV Lamp Operation.....	57
Training	57
Emergency Shower and Eyewash Installation, Use, Testing and Maintenance Policy	58
Responsibility	58
Department of Environmental Health & Safety.....	58
Campus Operations & Maintenance.....	58
Departments	58
Required Locations	59
New Equipment Installation Requirements.....	59
Use	59
Testing and Maintenance	60
Essential Biosafety Equipment.....	60
Eyewash Safety Training Handout	61

First Aid	62
Fire Safety in Labs	62
Flame Safety	63
Fume Hood Work Practices and Procedures	64
Glove Safety	65
Gloves and Lab Coats	65
Why Wearing Gloves is Important	65
When to Wear Gloves	65
When Not to Wear Gloves	66
Why Should We Wear Lab Coats?	66
When to Wear Lab Coats	66
When Not to Wear Lab Coats	66
Heat Disinfection and Sterilization	66
Autoclaving	67
Loading Autoclaves	67
Precautions in the Use of Autoclaves	67
Homogenizers, Shakers, Blenders and Sonicators	68
If you discover a fire, remain calm, do not shout "FIRE!"	68
Laboratory Design and Facilities	69
Design Features	69
Lab Safety Awareness for Non-Lab Staff	72
General Practices	72
Personal Protective Equipment and Clothing	72
Laboratory Coats, Gowns, Coveralls, Aprons	72
Goggles, Safety Spectacles, Face Shields	72
Respirators	73
Gloves	73
Putting On PPE	73
Taking Off PPE	74
Sharps Safety	74
Signs and Labels	75
No food or drink sign	75

Biosafety Door Sign	75
Biohazard Signs	76
Chemical Signs	76
Spill Clean-Up Procedure	79
Transport of Infectious Substances	79
The Basic Triple Packaging System.....	79
Packing and labelling of Category A infectious substances	80
Packing and labelling of Category B infectious substances	80
Use of Pipettes and Pipetting Aids.....	81
Working Alone in Research Labs	81
High School Students	81
Undergraduate Students	81
Graduate Students, Postdoctoral Fellows, Research Scientists, Technicians and Principal Investigators	82
Clinical Students, including Medical Students, Residents and Clinical	82

Prepared by
Safety officer of RCPN: A. Golchin.

Reviewed by
Dr. Y. Omidi, R. Ilghami.

RCPN

The Culture of Laboratory Safety

As a result of the promulgation of the Occupational Safety and Health Administration (OSHA) Laboratory Standard (29 CFR § 1910.1450), a culture of safety consciousness, accountability, organization, and education has developed in industrial, governmental, and academic laboratories. Laboratory personnel realize that the welfare and safety of each individual depends on clearly defined attitudes of teamwork and personal responsibility and that laboratory safety is not simply a matter of materials and equipment but also of processes and behaviors. Learning to participate in this culture of habitual risk assessment, experiment planning, and consideration of worst-case possibilities—for oneself and one's fellow workers—is as much part of a scientific education as learning the theoretical background of experiments or the step-by-step protocols for doing them in a professional manner.

Tips for Encouraging a Culture of Safety within an Academic Laboratory

- Make a topic of laboratory safety an item on every group meeting agenda.
- Periodically review the results of laboratory inspections with the entire group.
- Require that all accidents and incidents, even those that seem minor, are reported so that the cause can be identified.
- Review new experimental procedures with students and discuss all safety concerns. Where particularly hazardous chemicals or procedures are called for, consider whether a substitution with a less hazardous material or technique can be made.
- Make sure the safety rules within the laboratory (e.g., putting on eye protection at the door) are followed by everyone in the laboratory, from advisor to undergraduate researcher.
- Recognize and reward students and staff for attention to safety in the laboratory.



ABBREVIATIONS AND ACRONYMS

RCPN

BSC	Biological Safety Cabinet
BSL	Biosafety Level
CHP	Chemical Hygiene Plan
EAP	Emergency Action Plan
GMT	Good Microbiological Techniques
HEPA	High-Efficiency Particulate Arrestance
NSF	National Sanitation Foundation
PI	Principal Investigator
PPE	Personal Protective Equipment

RCPN



GLOSSARY

RCPN

Glossary

Accident	An unplanned event that results in injury, harm, or damage.
Administrative area	Dedicated room or adjoining rooms that are used for activities that do not involve infectious material and toxins. Administrative areas do not require any containment equipment, systems, or operational practices. Examples of administrative areas include offices, photocopy areas, and meeting/conference rooms.
Aerosol	A suspension of fine solid particles or liquid droplets in a gaseous medium (e.g., air) that can be created by any activity that imparts energy into a liquid/semi-liquid material.
Airborne pathogen	A pathogen that is capable of moving through or being carried by the air.
Airtight doors	Doors that are designed to allow no leakage of air (0%) under normal operating conditions and to withstand pressure decay testing and gaseous decontamination. Airtight doors can be achieved with inflatable or compression seals.
Animal cubicle	A room or space designed to house an animal (or animals) where the room itself serves as primary containment. These spaces are used to house large-sized animals (e.g., livestock, deer), or small sized animals that are housed in open caging (i.e., not primary containment caging).
Animal pathogen	Any pathogen that causes disease in animals; including those derived from biotechnology, animal pathogen” refers only to pathogens that cause disease in terrestrial animals; including those that infect avian and amphibian animals, but excluding those that cause disease in aquatic animals and invertebrates.

RCPN

Glossary

Animal room

A room designed to house animals in primary containment caging. These spaces are used to house only small-sized animals (e.g., mice, rats, rabbits).

Anteroom

A room, or series of rooms, inside the containment zone, used to separate “clean” areas from “dirty” areas (i.e., area with a lower risk of contamination from those with a higher risk of contamination), for personnel and animal entry/exit across the containment barrier, and for entry to/exit from animal rooms, animal cubicles, and post mortem rooms. The negative differential air pressures required in containment zones where inward directional airflow is provided can be more effectively maintained through the presence of an anteroom. An anteroom may also provide appropriate space at the entry/exit point(s) to don, doff and store dedicated containment zone clothing and additional personal protective equipment, as required.

Authorized personnel

Individuals who have been granted unsupervised access to the containment zone by the containment zone director, biological safety officer, or another individual to whom this responsibility has been assigned. This is dependent on completing training requirements and demonstrating proficiency in the standard operating procedures, as determined to be necessary by the facility.

Backdraft protection

A system that protects the air supply to the containment zone from contamination in the event of a reversal of air flow. High efficiency particulate air (HEPA) filters or isolation dampers are commonly used to prevent contamination from reaching areas of lower containment.

Backflow prevention

A system that protects the water supply to the containment zone from contamination. Many types of backflow devices also have test ports so that they can be checked to ensure that they are functioning properly.

General Principles

Introduction

Throughout this manual, references are made to the relative hazards of infective microorganisms by risk group (WHO Risk Groups 1, 2, 3 and 4). **This risk group classification is to be used for laboratory work only.** Table 1 describes the risk groups.

Table 1. Classification of infective microorganisms by risk group

Risk Group 1 (no or low individual and community risk)

A microorganism that is unlikely to cause human or animal disease.

Risk Group 2 (moderate individual risk, low community risk)

A pathogen that can cause human or animal disease but is unlikely to be a serious hazard to laboratory workers, the community, livestock or the environment. Laboratory exposures may cause serious infection, but effective treatment and preventive measures are available and the risk of spread of infection is limited.

Risk Group 3 (high individual risk, low community risk)

A pathogen that usually causes serious human or animal disease but does not ordinarily spread from one infected individual to another. Effective treatment and preventive measures are available.

Risk Group 4 (high individual and community risk)

A pathogen that usually causes serious human or animal disease and that can be readily transmitted from one individual to another, directly or indirectly. Effective treatment and preventive measures are not usually available.

Laboratory facilities are designated as basic – Biosafety Level 1, basic – Biosafety Level 2, containment – Biosafety Level 3, and maximum containment – Biosafety Level 4. Biosafety level designations are based on a composite of the design features, construction, containment facilities, equipment, practices and operational procedures required for working with agents from the various risk groups. Table 2 relates but **does not “equate”** risk groups to the biosafety level of laboratories designed to work with organisms in each risk group. Countries (regions) should draw up a national (regional) classification of microorganisms, by risk group, taking into account:

Table 2. Relation of risk groups to biosafety levels, practices and equipment

Risk Group	BIOSAFETY LEVEL	LABORATORY TYPE	LABORATORY PRACTICES	SAFETY EQUIPMENT
1	Basic –Biosafety Level 1	Basic teaching, research	GMT	None; open bench
2	Basic –Biosafety Level 2	Primary health services; diagnostic services, research	GMT plus protective clothing, biohazard sign	Open bench plus BSC for potential aerosols
3	Containment – Biosafety Level 3	Special diagnostic services, research	As Level 2 plus special clothing, controlled access, directional airflow	BSC and/or other primary devices for all activities
4	Maximum containment – Biosafety Level 4	Dangerous pathogen units	As Level 3 plus airlock entry, shower exit, special waste disposal	Class III BSC, or positive pressure suits in conjunction with Class II BSCs, double ended autoclave (through the wall), filtered air

BSC, biological safety cabinet; GMT, good microbiological techniques.

1. Pathogenicity of the organism.
2. Mode of transmission and host range of the organism. These may be influenced by existing levels of immunity in the local population, density and movement of the host population, presence of appropriate vectors, and standards of environmental hygiene.
3. Local availability of effective preventive measures. These may include: prophylaxis by immunization or administration of antisera (passive immunization); sanitary measures, e.g. food and water hygiene; control of animal reservoirs or arthropod vectors.
4. Local availability of effective treatment. This includes passive immunization, post exposure vaccination and use of antimicrobials, antivirals and chemotherapeutic agents, and should take into consideration the possibility of the emergence of drug-resistant strains.

The assignment of an agent to a biosafety level for laboratory work must be based on a risk assessment. Such an assessment will take the risk group as well as other factors into consideration in establishing the appropriate biosafety level. For example, an agent that is assigned to Risk Group 2 may generally require Biosafety Level 2 facilities, equipment, practices and procedures for safe conduct of work. However, if particular experiments require the generation of high-concentration aerosols, then Biosafety Level 3 may be more appropriate to provide the necessary degree of safety, since it ensures superior containment of aerosols in the laboratory workplace. The biosafety level assigned for the specific work to be done is therefore driven by professional judgment based on a risk assessment, rather than by automatic assignment of a laboratory biosafety level according to the particular risk group designation of the pathogenic agent to be used.

Table 3 summarizes the facility requirements at the four biosafety levels.

Table 3. Summary of biosafety level requirements

	BIOSAFETY LEVEL			
	1	2	3	4
Isolation ^a of laboratory	No	No	Yes	Yes
Room sealable for decontamination	No	No	Yes	Yes
Ventilation:				
— inward airflow	No	Desirable	Yes	Yes
— controlled ventilating system	No	Desirable	Yes	Yes
— HEPA-filtered air exhaust	No	No	Yes/No ^c	Yes
Double-door entry	No	No	Yes	Yes
Airlock	No	No	No	Yes
Airlock with shower	No	No	No	Yes
Anteroom	No	No	Yes	-
Anteroom with shower	No	No	Yes/No ^c	No
Effluent treatment	No	No	Yes/No ^c	Yes
Autoclave:				
— on site	No	Desirable	Yes	Yes
— in laboratory room	No	No	Desirable	Yes
— double-ended	No	No	Desirable	Yes
Biological safety cabinets	No	Desirable	Yes	Yes
Personnel safety monitoring capability ^d	No	No	Desirable	Yes

a Environmental and functional isolation from general traffic.

b Dependent on location of exhaust

c Dependent on agent(s) used in the laboratory.

d For example, window, closed-circuit television, two-way communication.

WHO Classification of Infective Microorganisms by Risk Group (2004)

- **WHO Risk Group 1:** (no or low individual and community risk). A microorganism that is unlikely to cause human disease or animal disease
- **WHO Risk Group 2:** (moderate individual risk, low community risk). A pathogen that can cause human or animal disease but is unlikely to be a serious hazard to laboratory workers, the community, livestock or the environment. Laboratory exposures may cause serious infection, but effective treatment and preventative measures are available and the risk of spread of infection is limited.
- **WHO Risk Group 3:** (high individual risk, low community risk). A pathogen that usually causes serious human or animal disease but does not ordinarily spread from one infected individual to another. Effective treatment and preventive measures are available.
- **WHO Risk Group 4:** (high individual and community risk). A pathogen that usually causes serious human or animal disease and that can be readily transmitted from one individual to another, directly or indirectly. Effective treatment and preventive measures are not usually available.

Accident/Injury Reports

All laboratory accidents must be reported to Lab Supervisors and Lab Safety Coordinators. This includes:

- Fires
- Explosions
- Large hazardous material spills
- Serious injuries (e.g., death, amputation, concussion, crushing, fracture, burn, laceration with serious bleeding or requiring stitches, or hospitalization)
- Laboratory-acquired infections
- Exposures to hazardous materials, including biohazardous material
- Incidents that have the potential to cause serious injury or harm

RCPN

It is also important for lab workers to report to the PI or Lab Manager all near misses that had the potential to cause serious injury or harm. Near misses provide you with the opportunity to correct potential hazards before an injury occurs.

The information that is needed in laboratory accidents includes:

- Injured person's name, address, etc
- Place of accident (be specific); Work location
- Specific type of injury (e.g. cut, sprain, chemical splash)
- Specific body part injured
- Was medical attention required (doctor or hospital)?
- Describe how accident occurred
- What do you think can be done to prevent this from reoccurring?
- Include any equipment involved in the incident
- What were the primary & contributing causes of the incident?

Immediate steps must be taken by the PI or Lab Manager to correct hazardous conditions or practices. The lab must document corrective actions that are taken, such as:

- Remove - *dangerous situations*
- Repair - *equipment, process*
- Replace - *damaged equipment*
- Retrain - *on-the-job training*
- Review - *update and correct SOPs*
- Assign responsibility and timeline for corrective actions

Animal Facilities

Animal Facility – Biosafety Level 1

This is suitable for the maintenance of most stock animals after quarantine (except nonhuman primates, regarding which national authorities should be consulted), and for animals that are deliberately inoculated with agents in Risk Group 1, GMT is required. The animal facility director must establish policies, procedures and protocols for all operations, and for access to the vivarium. An appropriate medical surveillance program for the staff must be instituted. A safety or operations manual must be prepared and adopted.

Animal Facility – Biosafety Level 2

This is suitable for work with animals that are deliberately inoculated with microorganisms in Risk Group 2. The following safety precautions apply:

1. All the requirements for animal facilities – Biosafety Level 1 must be met.
2. Biohazard warning signs (see Signs and Labels) should be posted on doors and other appropriate places.
3. The facility must be designed for easy cleaning and housekeeping.
4. Doors must open inwards and be self-closing.
5. Heating, ventilation and lighting must be adequate.
6. If mechanical ventilation is provided, the airflow must be inwards. Exhaust air is discharged to the outside and should not be recirculated to any part of the building.
7. Access must be restricted to authorized persons.
8. No animals should be admitted other than those for experimental use.
9. There should be an arthropod and rodent control program.
10. Windows, if present, must be secure, resistant to breakage and, if able to be opened, must be fitted with arthropod-proof screens.
11. After use, work surfaces must be decontaminated with effective disinfectants.
12. Biological safety cabinets (Classes I or II) or isolator cages with dedicated air supplies and HEPA-filtered exhaust air must be provided for work that may involve the generation of aerosols.
13. An autoclave must be available on site or in appropriate proximity to the animal facility.
14. Animal bedding materials must be removed in a manner that minimizes the generation of aerosols and dust.
15. All waste materials and bedding must be decontaminated before disposal.
16. Use of sharp instruments should be restricted whenever possible. Sharps should always be collected in puncture-proof/-resistant containers fitted with covers and treated as infectious.
17. Material for autoclaving or incineration must be transported safely, in closed containers.
18. Animal cages must be decontaminated after use.
19. Animal carcasses should be incinerated.
20. Protective clothing and equipment must be worn in the facility, and removed on leaving.
21. Hand-washing facilities must be provided. Staff must wash their hands before leaving the animal facility.
22. All injuries, however minor, must be treated appropriately, reported and recorded.
23. Eating, drinking, smoking and application of cosmetics must be forbidden in the facility.
24. All personnel must receive appropriate training.

Animal Facility – Biosafety Level 3

This is suitable for work with animals that are deliberately inoculated with agents in Risk Group 3, or when otherwise indicated by a risk assessment. All systems, practices and procedures need to be reviewed and recertified annually. The following safety precautions apply:

1. All the requirements for animal facilities – Biosafety Levels 1 and 2 must be met.
2. Access must be strictly controlled.
3. The facility must be separated from other laboratory and animal house areas by a room with a double-door entrance forming an anteroom.
4. Hand-washing facilities must be provided in the anteroom.
5. Showers should be provided in the anteroom.
6. There must be mechanical ventilation to ensure a continuous airflow through all the rooms. Exhaust air must pass through HEPA filters before being discharged to the atmosphere without recirculation. The system must be designed to prevent accidental reverse flow and positive pressurization in any part of the animal house.
7. An autoclave must be available at a location convenient for the animal house where the biohazard is contained. Infectious waste should be autoclaved before it is moved to other areas of the facility.
8. An incinerator should be readily available on site or alternative arrangements should be made with the authorities concerned.
9. Animals infected with Risk Group 3 microorganisms must be housed in cages in isolators or rooms with ventilation exhausts placed behind the cages.
10. Bedding should be as dust-free as possible.
11. All protective clothing must be decontaminated before it is laundered.
12. Windows must be closed and sealed, and resistant to breakage.
13. Immunization of staff, as appropriate, should be offered.

Animal Facility – Biosafety Level 4

Work in this facility will normally be linked with that in the maximum containment laboratory – Biosafety Level 4, and national and local rules and regulations must be harmonized to apply to both. If work is to be done in a suit laboratory, additional practices and procedures must be used over and above those described here.

1. All the requirements for animal facilities – Biosafety Levels 1, 2 and 3 must be met.
2. Access must be strictly controlled; only staff designated by the director of the establishment should have authority to enter.
3. Individuals must not work alone: the two-person rule must apply.
4. Personnel must have received the highest possible level of training as microbiologists and be familiar with the hazards involved in their work and with the necessary precautions.
5. Housing areas for animals infected with Risk Group 4 agents must maintain the criteria for containment described and applied for maximum containment laboratories – Biosafety Level 4.
6. The facility must be entered by an airlock anteroom, the clean side of which must be separated from the restricted side by changing and showering facilities.
7. Staff must remove street clothing when entering and put on special, protective clothing. After work they must remove the protective clothing for autoclaving, and shower before leaving.

8. The facility must be ventilated by a HEPA-filtered exhaust system designed to ensure a negative pressure (inward directional airflow).
9. The ventilation system must be designed to prevent reverse flow and positive pressurization.
10. A double-ended autoclave with the clean end in a room outside the containment rooms must be provided for exchange of materials.
11. A pass-through airlock with the clean end in a room outside the containment rooms must be provided for exchange of non-autoclavable materials.
12. All manipulations with animals infected with Risk Group 4 agents must take place under maximum containment – Biosafety Level 4 conditions.
13. All animals must be housed in isolators.
14. All animal bedding and waste must be autoclaved before removal from the facility.

Appropriate Clothing in Laboratories

General Lab Safety

- No eating or drinking in the lab
- Don't touch clean surfaces with gloves
- Shoes that are liquid resistant and cover your entire foot

Personal Protective Equipment

- Gloves
- Lab Coats
- Safety Goggles
- N95 Respirators – need to fit properly
- Handwashin

Gloves

- ✓ Multiple sizes for good fit
- ✓ Should fit snugly but not tight
- ✓ Double glove when working with known or concentrated hazards
- ✓ Remove one at a time – pull from cuffs, turning inside out as you go
- ✓ Discard into BioHazard Container
- ✓ NEVER wear outside of the lab

Lab Coats

- ✓ Be clean, neat and in good repair.
- ✓ Provide protection to the skin in the event of a chemical splash or spill
- ✓ Must be fluid resistant
- ✓ Do not wear outside of lab areas
- ✓ Must cover arms and lap when sitting
- ✓ Must be snapped/button closed

Safety Goggles

- ✓ Fit snugly against the face
- ✓ Should not slip
- ✓ Must have side shield panels
- ✓ Variety of Styles
- ✓ Regular/Standard
- ✓ Over Glasses
- ✓ Anti-fog

N95 Respirators – need to fit properly

- ✓ Must fit properly to be effective
- ✓ Fit checks should be done in advance and
- ✓ annually
- ✓ Seal around the face

Hand washing

- ✓ Wet both hands and rinse well before applying
- ✓ Soap – warm water
- ✓ Apply soap from dispenser
- ✓ Lather well over front and back of hands
- ✓ Wash for 20 seconds (Happy Birthday song twice)
- ✓ Rinse hands from wrists down
- ✓ Dry well with paper towel

RCPN

Biological Hazard Operations

Table 3. Biological hazard operations

	BSL 1	BSL 2	BSL3
Examples	<ul style="list-style-type: none"> • <i>E. Coli K12</i> • <i>Saccharomyces cerevisiae</i> 	<ul style="list-style-type: none"> • Human cells, blood, tissue • <i>Salmonella sp.</i> • <i>Polio Virus</i> 	<ul style="list-style-type: none"> • <i>Mycobacterium tuberculosis</i> • <i>Hanta Virus</i>
Agents	Not known to cause disease in healthy adults	Associated with human disease. Hazard from percutaneous injury, ingestion, mucous membrane exposure.	Indigenous or exotic agents with potential for aerosol transmission; disease may have serious or lethal consequences.
Work Practices	Standard Microbiological Practices	BSL1 Plus: <ul style="list-style-type: none"> • Limit access • Biohazard warning signs • Sharps precautions • Biosafety Manual/SOPs defining any needed waste decontamination or medical surveillance.	BSL2 Plus: <ul style="list-style-type: none"> • Controlled access • Decontamination of all waste • Decontamination of lab clothing before laundering
Engineering Controls		Biosafety cabinet for all manipulations of agents that cause splashes or aerosols of infectious materials, including pipetting, centrifuging, tissue culture & sonication.	<ul style="list-style-type: none"> • Biosafety cabinet for all open manipulations of agents • Constantly monitored directional air flow into lab
PPE		<ul style="list-style-type: none"> • Lab coat • Gloves • Face protection based on risk assessment 	<ul style="list-style-type: none"> • Protective lab clothing • Gloves • Respirator based on risk assessment
Designated Area	Open bench top sink required	<ul style="list-style-type: none"> • Secure storage of infectious agents • Lab locked when unoccupied 	<ul style="list-style-type: none"> • Physical separation from access corridors • Self-closing, double door access • Exhaust air not recirculated

Biological Safety Work Practices

A. The term "containment" is used in describing methods for managing infectious agents in the laboratory environment where they are being handled or maintained. The purpose of containment is to reduce exposure of laboratory workers, other persons, and the outside environment to potentially hazardous agents. The three elements of containment include laboratory practices and techniques, safety equipment, and facility design.

a. Primary containment, the protection of personnel and the immediate laboratory environment from exposure to infectious agents, is provided by good technique and the use of appropriate safety equipment.

b. Secondary containment, the protection of external laboratory environment from exposure to infectious materials, is provided by a combination of facility design and operational practices.

B. Laboratory Practice and Technique. The most important element of containment is strict adherence of standard biohazard practices and techniques. Persons working with infectious agents or infected materials must be aware of potential hazards and be trained and proficient in the practices and techniques required for handling such material safely. The supervisor is responsible for providing or arranging for appropriate training of personnel.

C. Additional measures may be necessary when standard laboratory practices are not sufficient to control the hazard associated with a particular agent or laboratory procedure. The selection of additional safety practices is the responsibility of the laboratory supervisor and must be commensurate with the inherent risk associated with the agent or procedure.

1. To reduce the risk of injury due to breakage of glass capillary tubes, laboratories should adopt blood collection devices that are less prone to accidental breakage, including

1. Capillary tubes not made of glass

2. Glass capillary tubes wrapped in puncture-resistant film

3. Products that use a method of sealing that does not require manually pushing one end of the tube into putty to form a plug

D. Each laboratory must develop or adopt a safety or operational manual which identifies the hazards that will or may be encountered and which specify practices and procedures designed to minimize or eliminate identified risks. Personnel should be advised of special hazards and should be required to read and to follow the required practices and procedures. In the Microbiology Laboratory activities must be supervised by a microbiologist who is trained and knowledgeable in appropriate laboratory techniques, safety procedures, and associated risks.

F. Laboratory personnel safety practices and techniques must be supplemented by appropriate facility design and engineering features, safety equipment, and management practices.

G. Biosafety Levels. These guidelines specify four Biosafety levels (BSLS) which consist of combinations of laboratory practices and techniques, safety equipment, and laboratory facilities which are commensurate with the operations performed and with the potential hazard posed by the infectious agents for which the laboratory is responsible.

H. The object of these guidelines is to inform the laboratory staff of the RCPN institution when handling potentially hazardous organisms and biological materials.

I. Each laboratory worker is responsible for:

1. The safety of his/her fellow worker
2. His/her own safety
3. Training in the safety methods used in the laboratory

It should be remembered that the most expensive equipment is not a substitute for careful technique.

J. Medical Examination

Medical evaluations with special attention to factors appropriate to the origin most involved are given by Occupational Health Services.

1. Occupational Health Services will determine the immune status of new employees for *Hepatitis B*, *Rubeola*, *Varicella Zoster*, and *Rubella* and appropriate vaccinations will be offered.
2. Semi-annual tuberculin tests are administered to all Microbiology personnel. Annual tuberculin tests are administered to all other departmental personnel. If a tuberculin test becomes newly positive, a chest x-ray is performed.
3. Pregnant women are not known to be at greater risk of contracting blood-borne infections than other laboratory workers. However, if *HBV* or *HIV* infection develops during pregnancy or if the mother carries these viruses prior to pregnancy, the infant is at risk of infection by perinatal transmission. Therefore, pregnant laboratory workers carry added responsibility for attention to safety precaution.

K. The laboratory function is based on the quantities of organisms or activities involving infected animals.

1. **Function A:** Activities involve the use or manipulation of small quantities or low concentrations of cultures or other materials known or suspected of containing the agent.
2. **Function B:** Activities involve the use or manipulation of large quantities or high concentrations of cultures or other materials known or suspected of containing the agent.
3. **Function C:** Activities involve the use or manipulation of vertebrate animals with natural or induced infection with the agent.
4. **Function D:** The importation, possession, and use of *variola major*, *variola minor*, and *whitepox* viruses which is restricted to the designated World Health Organization Collaborating Center for *Poxviruses*.

Biological Safety Cabinets

Biological safety cabinets (BSCs) are designed to protect the operator, the laboratory environment and work materials from exposure to infectious aerosols and splashes that may be generated when manipulating materials containing infectious agents, such as primary cultures, stocks and diagnostic specimens. Aerosol particles are created by any activity that imparts energy into a liquid or semiliquid material, such as shaking, pouring, stirring or dropping liquid onto a surface or into another liquid. Other laboratory activities, such as streaking agar plates, inoculating cell culture flasks with a pipette, using a multichannel pipette to dispense liquid suspensions of infectious agents into microculture plates, homogenizing and vortexing infectious materials, and centrifugation of infectious liquids, or working with animals, can generate infectious aerosols. Aerosol particles of less than 5 μm in diameter and small droplets of 5–100 μm in diameter are not visible to the naked eye. The laboratory worker is generally not aware that such particles are being generated and may be inhaled or may cross-contaminate work surface materials. BSCs, when properly used, have been shown to be highly effective in reducing laboratory-acquired infections and cross-contaminations of cultures due to aerosol exposures. BSCs also protect the environment. Over the years the basic design of BSCs has undergone several modifications. A major change was the addition of a high-efficiency particulate air (HEPA) filter to the exhaust system. The HEPA filter traps 99.97% of particles of 0.3 μm in diameter and 99.99% of particles of greater or smaller size. This enables the HEPA filter to effectively trap all known infectious agents and ensure that only microbe-free exhaust air is discharged from the cabinet. A second design modification was to direct HEPA-filtered air over the work surface, providing protection of work surface materials from contamination. This feature is often referred to as product protection. These basic design concepts have led to the evolution of three classes of BSCs. The type of protection provided by each is set out in Table 4.

Note. Horizontal and vertical outflow cabinets (“clean-air work stations”) are **not** biological safety cabinets and should not be used as such.

Table 4. Selection of a biological safety cabinet (BSC), by type of protection needed

TYPE OF PROTECTION	BSC SELECTION
Personnel protection, Microorganisms in Risk Groups 1–3	Class I, Class II, Class III
Personnel protection, microorganisms in Risk Group 4, glove-box laboratory	Class III
Personnel protection, microorganisms in Risk Group 4, suit laboratory	Class I, Class II
Product protection	Class II, Class III only if laminar flow included
Volatile radionuclide/chemical protection, minute amounts	Class IIB1, Class IIA2 vented to the outside
Volatile radionuclide/chemical protection	Class I, Class IIB2, Class III

Class I Biological Safety Cabinet

Figure 1 provides a schematic diagram of a Class I BSC. Room air is drawn in through the front opening at a minimum velocity of 0.38 m/s, it passes over the work surface and is discharged from the cabinet through the exhaust duct. The directional flow of air whisks aerosol particles that may be generated on the work surface away from the laboratory worker and into the exhaust duct. The front opening allows the operator's arms to reach the work surface inside the cabinet while he or she observes the work surface through a glass window. The window can also be fully raised to provide access to the work surface for cleaning or other purposes.

The air from the cabinet is exhausted through a HEPA filter: (a) into the laboratory and then to the outside of the building through the building exhaust; (b) to the outside through the building exhaust; or (c) directly to the outside. The HEPA filter may be located in the exhaust plenum of the BSC or in the building exhaust. Some Class I BSCs are equipped with an integral exhaust fan, whereas others rely on the exhaust fan in the building exhaust system. The Class I BSC was the first recognized BSC and, because of its simple design, is still in wide use throughout the world. It has the advantage of providing personnel and environmental protection and can also be used for work with radionuclides and volatile toxic chemicals. Because unsterilized room air is drawn over the work surface through the front opening, it is not considered to provide consistently reliable product protection.

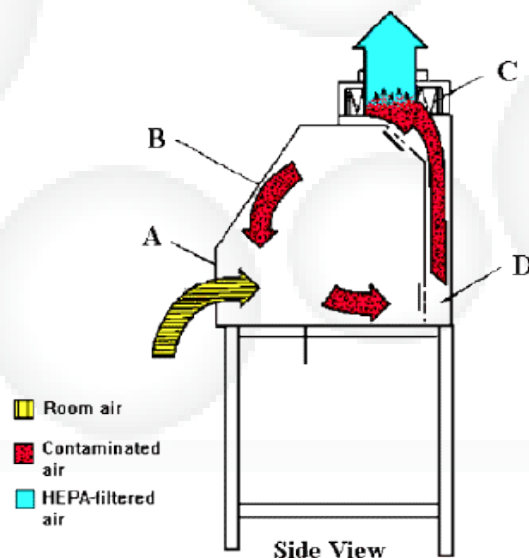

Figure1. Schematic diagram of a Class I biological safety cabinet.
A, front opening; B, sash; C, exhaust HEPA filter; D, exhaust plenum.

Class II Biological Safety Cabinets

As the use of cell and tissue cultures for the propagation of viruses and other purposes grew, it was no longer considered satisfactory for unsterilized room air to pass over the work surface. The Class II BSC was designed not only to provide personnel protection but also to protect work surface materials from contaminated room air. Class II BSCs, of which there are four types (A1, A2, B1 and B2), differ from Class I BSCs by allowing only air from a HEPA-filtered (sterile) supply

to flow over the work surface. The Class II BSC can be used for working with infectious agents in Risk Groups 2 and 3. Class II BSCs can be used for working with infectious agents in Risk Group 4 when positive-pressure suits are used.

Class II Type A1 Biological Safety Cabinet

The Class II type A1 BSC is shown in Figure 2. An internal fan draws room air (supply air) into the cabinet through the front opening and into the front intake grill. The inflow velocity of this air should be at least 0.38 m/s at the face of the front opening. The supply air then passes through a supply HEPA filter before flowing downwards over the work surface. As the air flows downwards it “splits” about 6–18 cm from the work surface, one half of the downwards flowing air passing through the front exhaust grill, and the other half passing through the rear exhaust grill. Any aerosol particles generated at the work surface are immediately captured in this downward airflow and passed through the front or rear exhaust grills, thereby providing the highest level of product protection. The air is then discharged through the rear plenum into the space between the supply and exhaust filters located at the top of the cabinet. Owing to the relative size of these filters, about 70% of the air recirculates through the supply HEPA filter back into the work zone; the remaining 30% passes through the exhaust filter into the room or to the outside.

Air from the Class IIA1 BSC exhaust can be recirculated to the room or discharged to the outside of the building through a thimble connection to a dedicated duct or through the building exhaust system. Recirculating the exhaust air to the room has the advantage of lowering building fuel costs because heated and/or cooled air is not being passed to the outside environment. A connection to a ducted exhaust system also allows some BSCs to be used for work with volatile radionuclides and volatile toxic chemicals (Table 4).

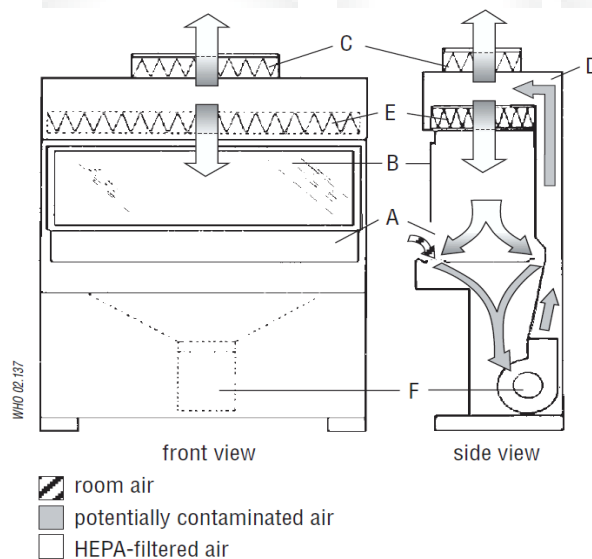

Figure2. Schematic representation of a Class IIA1 biological safety cabinet. A, front opening; B, sash; C, exhaust HEPA filter; D, rear plenum; E, supply HEPA filter; F, blower.

Class II type A2 vented to the outside, B1 and B2 biological safety cabinets

Class IIA2 vented to the outside, IIB1 (Figure 3) and IIB2 BSCs are variations of the type IIA1. Their characteristics, along with those of Class I and Class III BSCs, are indicated in Table 5. Each variation allows the BSC to be used for specialized purposes. These BSCs differ from one another in several aspects: the air intake velocity through the front opening; the amount of air recirculated over the work surface and exhausted from the cabinet; the exhaust system, which determines whether air from the cabinet is exhausted to the room, or to the outside, through a dedicated exhaust system or through the building exhaust; and the pressure arrangements (whether cabinets have biologically contaminated ducts and plenums under negative pressure, or have biological contaminated ducts and plenums surrounded by negative pressure ducts and plenums).

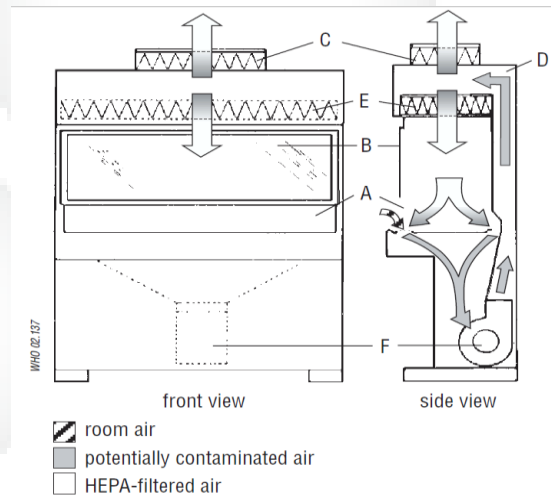

Figure3. Schematic diagram of a Class IIB1 biological safety cabinet
A, front opening; B, sash; C, exhaust HEPA filter; D, rear plenum; E, supply HEPA filter; F, blower.

Table5. Differences between Class I, II and III biological safety cabinets (BSCs)

BSC	FACE VELOCITY (m/s)	AIRFLOW (%)		EXHAUST SYSTEM
		RECIRCULATED	EXHAUSTED	
Class I ^a	0.36	0	100	Hard duct
Class IIA1	0.38–0.51	70	30	Exhaust to room or thimble connection
Class IIA2	0.51	70	30	Exhaust to room or thimble connection
vented to the outside^a				
Class IIB1 ^a	0.51	30	70	Hard duct
Class IIB2 ^a	0.51	0	100	Hard duct
Class III ^a	NA	0	100	Hard duct

NA, not applicable.

^a All biologically contaminated ducts are under negative pressure or are surrounded by negative pressure ducts and plenums.

Class III Biological Safety Cabinet

This type (Figure 4) provides the highest level of personnel protection and is used for Risk Group 4 agents. All penetrations are sealed “gas tight”. Supply air is HEPA-filtered and exhaust air passes through two HEPA filters. Airflow is maintained by a dedicated exhaust system exterior to the cabinet, which keeps the cabinet interior under negative pressure (about 124.5 Pa). Access to the work surface is by means of heavy duty rubber gloves, which are attached to ports in the cabinet. The Class III BSC should have an attached pass-through box that can be sterilized and is equipped with a HEPA-filtered exhaust. The Class III cabinet may be connected to a double-door autoclave used to decontaminate all materials entering or exiting the cabinet. Several glove boxes can be joined together to extend the work surface. Class III BSCs are suitable for work in Biosafety Level 3 and 4 laboratories.

Biological Safety Cabinet Air Connections

A “thimble” or “canopy hood” is designed for use with Class IIA1 and IIA2 vented to the outside BSCs. The thimble fits over the cabinet exhaust housing, sucking the cabinet exhaust air into the building exhaust ducts. A small opening, usually 2.5 cm in diameter, is maintained between the thimble and the cabinet exhaust housing. This small opening enables room air to be sucked into the building exhaust system as well. The building exhaust capacity must be sufficient to capture both room air and the cabinet exhaust. The thimble must be removable or be designed to allow for operational testing of the cabinet. Generally, the performance of a thimble-connected BSC is not affected much

by fluctuations in the airflow of the building Class IIB1 and IIB2 BSCs are hard-ducted, i.e. firmly connected without any openings, to the building exhaust system or, preferably, to a dedicated exhaust duct system. The building exhaust system must be precisely matched to the airflow requirements specified by the manufacturer for both volume and static pressure. Certification of hard-duct connected BSCs is more time-consuming than that for BSCs that recirculate air to the room or which are thimble-connected.

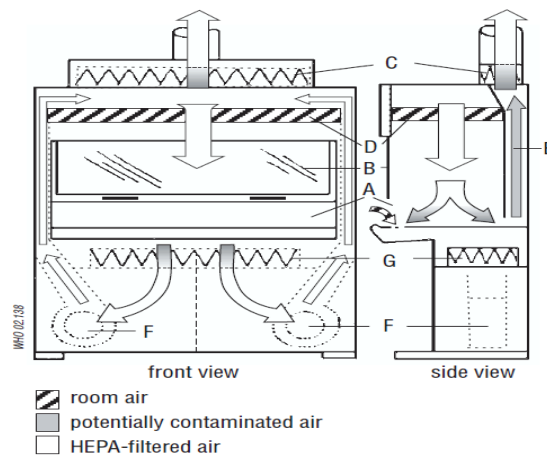

Figure4. Schematic representation of a Class III biological safety cabinet (glove box).
A, front opening; B, sash; C, exhaust HEPA filter; D, supply HEPA filter; E, negative pressure

exhaust plenum; F, blower; G, HEPA filter for supply air. Connection of the cabinet exhaust to the building exhaust air system is required.

Selection of a Biological Safety Cabinet

A BSC should be selected primarily in accordance with the type of protection needed: product protection; personnel protection against Risk Group 1–4 microorganisms; personnel protection against exposure to radionuclides and volatile toxic chemicals; or a combination of these. Table 8 shows which BSCs are recommended for each type of protection. Volatile or toxic chemicals should not be used in BSCs that recirculate exhaust air to the room, i.e. Class I BSCs that are not ducted to building exhaust systems, or Class IIA1 or Class IIA2 cabinets. Class IIB1 BSCs are acceptable for work with minute amounts of volatile chemicals and radionuclides. A Class IIB2 BSC, also called a total exhaust cabinet, is necessary when significant amounts of radionuclides and volatile chemicals are expected to be used.

Using Biological Safety Cabinets in the Laboratory Location

The velocity of air flowing through the front opening into a BSC is about 0.45 m/s. At this velocity the integrity of the directional air inflow is fragile and can be easily disrupted by air currents generated by people walking close to the BSC, open windows, air supply registers, and opening and shutting doors. Ideally, BSCs should be situated in a location remote from traffic and potentially disturbing air currents. Whenever possible a 30-cm clearance should be provided behind and on each side of the cabinet to allow easy access for maintenance. A clearance of 30–35 cm above the cabinet may be required to provide for accurate air velocity measurement across the exhaust filter and for exhaust filter changes.

Operators

If BSCs are not used properly, their protective benefits may be greatly diminished. Operators need to be careful to maintain the integrity of the front opening air inflow when moving their arms into and out of cabinets. Arms should be moved in and out slowly, perpendicular to the front opening. Manipulations of materials within BSCs should be delayed for about 1 min after placing hands and arms inside to allow the cabinet to adjust and to “air sweep” the surface of the hands and arms. The number of movements across the front opening should also be minimized by placing all necessary items into the cabinet before beginning manipulations.

Material Placement

The front intake grill of Class II BSCs must not be blocked with paper, equipment or other items. Materials to be placed inside the cabinet should be surface-decontaminated with 70% alcohol. Work may be performed on disinfectant-soaked absorbent towels to capture splatters and splashes. All materials should be placed as far back in the cabinet, towards the rear edge of the work surface, as practical without blocking the rear grill. Aerosol-generating equipment (e.g. mixers, centrifuges, etc.) should be placed towards the rear of the cabinet. Bulky items, such as biohazard bags, discard pipette trays and suction collection flasks should be placed to one side of the interior of the cabinet. Active work should flow from clean to contaminated areas across the work surface.

The autoclavable biohazard collection bag and pipette collection tray should not be placed outside the cabinet. The frequent in-and-out movement needed to use these containers is disruptive to the integrity of the cabinet's air barrier, and can compromise both personnel and product protection.

Operation and Maintenance

Most BSCs are designed to permit operation 24 h/day, and investigators find that continuous operation helps to control the levels of dust and particulate materials in the laboratory. Class IIA1 and IIA2 BSCs exhausting to the room or connected by thimble connections to dedicated exhaust ducts can be turned off when not in use. Other types such as IIB1 and IIB2 BSCs, which have hard-duct installations, must have airflow through them at all times to help maintain room air balance. Cabinets should be turned on at least 5 min before beginning work and after completion of work to allow the cabinet to "purge", i.e. to allow time for contaminated air to be removed from the cabinet environment. All repairs made on BSCs should be made by a qualified technician. Any malfunction in the operation of the BSC should be reported and repaired before the BSC is used again.

Ultraviolet Lights

Ultraviolet lights are not required in BSCs. If they are used, they must be cleaned weekly to remove any dust and dirt that may block the germicidal effectiveness of the light. Ultraviolet light intensity should be checked when the cabinet is recertified to ensure that light emission is appropriate. Ultraviolet lights must be turned off while the room is occupied, to protect eyes and skin from inadvertent exposure.

Open Flames

Open flames should be avoided in the near microbe-free environment created inside the BSC. They disrupt the airflow patterns and can be dangerous when volatile, flammable substances are also used. To sterilize bacteriological loops, microburners or electric "furnaces" are available and are preferable to open flames.

Spills

A copy of the laboratory's protocol for handling spills should be posted, read and understood by everyone who uses the laboratory. When a spill of biohazardous material occurs within a BSC, clean-up should begin immediately, while the cabinet continues to operate. An effective disinfectant should be used and applied in a manner that minimizes the generation of aerosols. All materials that come into contact with the spilled agent should be disinfected and/or autoclaved.

Certification

The functional operation and integrity of each BSC should be certified to national or international performance standards at the time of installation and regularly thereafter by qualified technicians, according to the manufacturer's instructions. Evaluation of the effectiveness of cabinet containment should include tests for cabinet integrity, HEPA filter

leaks, down flow velocity profile, face velocity, negative pressure/ventilation rate, air-flow smoke pattern, and alarms and interlocks. Optional tests for electrical leaks, lighting intensity, ultraviolet light intensity, noise level and vibration may also be conducted. Special training, skills and equipment are required to perform these tests and it is highly recommended that they are undertaken by a qualified professional.

Cleaning and Disinfection

All items within BSCs, including equipment, should be surface-decontaminated and removed from the cabinet when work is completed, since residual culture media may provide an opportunity for microbial growth. The interior surfaces of BSCs should be decontaminated before and after each use.

The work surfaces and interior walls should be wiped with a disinfectant that will kill any microorganisms that might be found inside the cabinet. At the end of the work day, the final surface decontamination should include a wipe-down of the work surface, the sides, back and interior of the glass. A solution of bleach or 70% alcohol should be used where effective for target organisms. A second wiping with sterile water is needed when a corrosive disinfectant, such as bleach, is used.

It is recommended that the cabinet is left running. If not, it should be run for 5 min in order to purge the atmosphere inside before it is switched off.

Decontamination

BSCs must be decontaminated before filter changes and before being moved. The most common decontamination method is by fumigation with formaldehyde gas. BSC decontamination should be performed by a qualified professional.

Personal Protective Equipment

Personal protective clothing should be worn whenever using a BSC. Laboratory coats are acceptable for work being performed at Biosafety Levels 1 and 2. A solid front, back-closing laboratory gown provides better protection and should be used at Biosafety Levels 3 and 4 (except for suit laboratories). Gloves should be pulled over the wrists of the gown rather than worn inside. Elasticized sleeves can be worn to protect the investigator's wrists. Masks and safety glasses may be required for some procedures.

Alarms

BSCs can be equipped with one of two kinds of alarm. Sash alarms are found only on cabinets with sliding sashes. The alarm signifies that the operator has moved the sash to an improper position. Corrective action for this type of alarm is returning the sash to the proper position. Airflow alarms indicate a disruption in the cabinet's normal airflow pattern. This represents an immediate danger to the operator or product. When an airflow alarm sounds, work should cease immediately and the laboratory supervisor should be notified. Manufacturers' instruction manuals should provide further details. Training in the use of BSCs should cover this aspect.

Supplementary Information

Selecting the correct type of BSC, installing it, using it properly and annually certifying its operation are complex processes. It is highly recommended that they proceed under the supervision of a well-trained and experienced biosafety professional. The professional should be highly familiar with the relevant literature listed in the References section, and should have been trained on all aspects of BSCs. Operators should receive formal training in the operation and use of BSCs.

Biohazard Warning Sign

Figure 5. Biohazard warning sign for laboratory doors



BIOHAZARD

ADMITTANCE TO AUTHORIZED PERSONNEL ONLY

Biosafety Level: _____

Responsible Investigator: _____

In case of emergency call: _____

Daytime phone: _____ Home phone: _____

Authorization for entrance must be obtained from the Responsible Investigator named above.

Care and Use of Refrigerators and Freezers

1. Refrigerators, deep-freezers and solid carbon dioxide (dry-ice) chests should be defrosted and cleaned periodically, and any ampoules, tubes, etc. that have broken during storage removed. Face protection and heavy duty rubber gloves should be worn during cleaning. After cleaning, the inner surfaces of the cabinet should be disinfected.
2. All containers stored in refrigerators, etc. should be clearly labelled with the scientific name of the contents, the date stored and the name of the individual who stored them. Unlabelled and obsolete materials should be autoclaved and discarded.

3. An inventory must be maintained of the freezer's contents.
4. Flammable solutions must not be stored in a refrigerator unless it is explosion proof. Notices to this effect should be placed on refrigerator doors.

Centrifuge and Rotor Safety Guide

Three factors that govern a safe life for any rotor are:

- Design and manufacture
- Proper care and handling during use
- Retirement, when damage or fatigue make continued use unsafe

Proper care and handling include:

1. Record the purchase date of each rotor, along with manufacturing date and serial number.
2. Read the manuals for the rotors and tubes before using the equipment. Follow all operational specifications published in each rotor manual.
3. Rotors must be used with the correct centrifuge (Beckman rotors in Beckman centrifuges). Proper rotor and centrifuge combinations will meet laboratory equipment standards and regulations of UL.
4. Maximum speed and sample density ratings designated by the manufacturer for each rotor are intended to prevent stress failures and should always be observed.
5. Speed reductions required for running high-density solutions, plastic adapters, or stainless steel tubes should always be observed.
6. Sample loads must be balanced and swinging bucket rotors must not be run with missing buckets.
7. Before running an ultracentrifuge, check the classification decal on the ultracentrifuge and make sure it matches the classification decal on the rotor.
8. The correct overspeed disk must be used with ultracentrifuges. The disk must be on the bottom of the rotor and the disk must be in good condition.
9. A speed-derating disk must be installed if and when the warranty conditions require it.
10. A well-kept rotor log is essential for continued safe operation of an ultracentrifuge. Include date, user, rotor used, and any problems encountered.

- 11.** Set the proper run speed on each time to prevent overspeeding.
- 12.** Use a titanium rotor if corrosive salt solutions will be used frequently.
- 13.** Do not scratch or otherwise damage the aluminum oxide layer that protects the underlying metal.
- 14.** Rotor cavities and buckets must never be cleaned with an ordinary bottle brush with sharp wire ends. Use special plastic coated brushes.
- 15.** Do not use alkaline detergents or cleaning solutions that may remove the anodized coating. Most commercially available solutions for radioactive decontamination are highly alkaline.
- 16.** If corrosive materials have been run or spilled on the rotor, wash it immediately.
- 17.** Clean all spills or breakage involving radiological, toxic, pathogenic or biological material immediately. Refer to appropriate safety guides for information.
- 18.** Only wash the buckets of a swinging bucket rotor. The body of the rotor should never be immersed: the hanger mechanisms are hard to dry and can rust.
- 19.** Air-dry the rotor after it has been cleaned and thoroughly rinsed with water.
- 20.** Store all fixed angle vertical tube and near-vertical tube rotors upside down, with the lids or plugs removed.
- 21.** Swinging bucket rotors should be stored with the bucket caps removed.
- 22.** Store all rotors in a dry environment, not in the centrifuge.
- 23.** Lubricate O-rings and threads as recommended by the manufacturer.
- 24.** Observe warranty period and retirement recommendations for each class of rotor.
- 25.** Consideration should be given to retiring the rotor when the warranty period has expired.
- 26.** Do not use a rotor after the expiration date permanently marked (on some models) on the rotor or rotor accessories. The components must be taken out of service.
- 27.** If using centrifuges with Biosafety Level 2 or higher material, rotors must have aerosol containment ("O-rings") or be used in a biosafety cabinet. Rotors must be loaded and unloaded in a biosafety cabinet.
- 28.** If using centrifuges with radioactive material, keep centrifuge behind an appropriate shield.

29. Rotors and accessories must be made non-radioactive, non-pathogenic, non-toxic and otherwise safe prior to maintenance or repair. A signed statement must be included with the equipment.

Emergency Equipment

The following is a guide to safety equipment found in a laboratory.

1. A written emergency action plan (EAP) has been developed and communicated to all personnel in the unit. The plan includes procedures for evacuation, ventilation failure, first aid, and incident reporting.
2. Fire extinguishers are available in the laboratory and tested on a regular basis. If a fire extinguisher is activated for any reason, make an immediate report of the activity, fire marshal, or appropriate individual responsible for fire safety equipment so that the fire extinguisher is replaced in a timely manner.
3. Eyewash units are available, inspected, and tested on a regular basis.
4. Safety showers are available and tested routinely.
5. Fire blankets are available in the laboratory, as required. Fire blankets can be used to wrap a burn victim to douse flames as well as to cover a shock victim and to provide a privacy shield when treating a victim under a safety shower in the event of a chemical spill.
NOTE: Laboratory personnel should be taught that fire blankets can be dangerous if used incorrectly. Wrapping a fire blanket around a person on fire can result in a chimney-like effect that intensifies, rather than extinguishes, the fire. Fire blankets should never be used on a person when they are standing.
6. First-aid equipment is accessible, whether through a kit available in the laboratory or by request through the organization.
7. Fire alarms and telephones are available and accessible for emergency use.
8. Pathways to fire extinguishers, eyewash units, fire blankets, first-aid kits, and safety showers are clear.

RCPN

Chemical Hazard Operations

Table 6. Chemical Hazard Operations

	Low	Medium	High
Examples	Buffers Glycerin	Ethanol Hydrochloric acid Hydrogen peroxide Methyl methacrylate	Ethidium bromide Formaldehyde Hydrofluoric acid Methylene chloride Phenol
Hazard Class	Chemicals that are: *relatively harmless to slightly toxic have no potential for uncontrolled process hazards AND Staff have previous experience with the type of work.	Corrosive Flammable Heavy Metal Lachrymator Neurotoxin Oxidizer Peroxide or Peroxide forming Reactive Sensitizer Toxic	Carcinogens Reproductive Hazards Acutely Toxic Severe Allergen/Sensitizer Explosive Pyrophoric Strong Corrosive Strong Oxidizers Strong Reducing agent Strong Sensitizers Unstable Water Reactive
Work Practices	Good Laboratory Practices	<p>Low Plus:</p> <ul style="list-style-type: none"> *Have written Standard Operating Procedure available for procedures. *Ensure that all laboratory users are familiar with SOPs. *Wash hands and any other potentially exposed skin immediately after working with chemicals. *Cover work surfaces with absorbent plastic backed paper to simplify clean-up. *Conduct exposure monitoring and medical consultations if required by Hazard Review. 	<p>Medium Plus:</p> <ul style="list-style-type: none"> *Substitute acutely toxic substances with less toxic alternative. *Use the smallest amount of material practical. *Everyone working with High Hazard chemicals must receive additional training on the special control measures required. * Only personnel with special instruction on the hazards and safe handling of the High Hazard substances must be permitted access to the areas.

Table 6. Chemical Hazard Operations

	Low	Medium	High
Engineering Controls	-	<ul style="list-style-type: none"> • Use a fume hood if material is volatile or the process may produce aerosols. • Use appropriate storage containers for raw materials and waste materials (e.g., flammable safety cans). 	<ul style="list-style-type: none"> • Containment devices, such as fume hoods or glove boxes, must be used when conducting any manipulation, handling or reaction that may result in the uncontrollable release of the particularly hazardous chemical. • Fume hoods must have a continuous air flow monitor or other mechanism for ensuring the performance of the hood. • Glove boxes must be used under negative pressure. The gloves must be checked for integrity and compatibility with the hazardous substance.
PPE	-	<ul style="list-style-type: none"> • Glove material must be compatible with chemical. • Laboratory coat with long sleeves worn closed (snaps are preferred). • Safety goggles. 	<ul style="list-style-type: none"> • PPE should be disposable. • Reusable PPE must be appropriately decontaminated after use. • Double gloves should be used. • PPE used with high hazard operations must be removed in the designated area. • Hands, neck, arms and face must be washed after removing contaminated PPE.
Designated Area	-	-	<ul style="list-style-type: none"> • All entrances to a laboratory or storage area where High Hazard materials are present must be posted with sign indicating the use of specific hazard classes and state "Authorized Personnel Only". • Designated areas can be the entire laboratory, a portion of the laboratory,

or equipment, such as the fume hood or glove box.

- The sign must include the name of the hazardous chemical or process, and the appropriate hazard warning.

Chemical Hygiene Plan

Chemical hygiene plan was created to minimize employee exposure to hazardous chemicals in the laboratory and sets forth guidelines for employers and trained laboratory personnel engaged in the use of hazardous chemicals. The Laboratory Standard defines a Chemical Hygiene Plan (CHP) as “a written program developed and implemented by the employer which sets forth procedures, equipment, personal protective equipment and work practices that are capable of protecting employees from the health hazards presented by hazardous chemicals used in that particular workplace.” Where hazardous chemicals as defined by this standard are used in the workplace, the employer shall develop and carry out the provisions of a written Chemical Hygiene Plan. The CHP is the foundation of the laboratory safety program and should be reviewed and updated, as needed, on an annual basis to reflect changes in policies and personnel. A CHP that is facility specific can assist in promoting a culture of safety to protect employees from exposure to hazardous materials.

1. Individual responsibilities for chemical hygiene within the organization
2. Emergency preparedness and facility security issues,
3. Personal apparel and PPE,
4. Chemical management,
5. Laboratory housekeeping,
6. Standard operating procedures,
7. Emergency action plan (EAP) for accidents and spills,
8. Safety equipment,
9. Chemical waste policies,
10. Required training,
11. Safety rules and regulations,
12. Facility design and laboratory ventilation,
13. Medical and environmental monitoring,
14. Compressed gas safety,
15. Laboratory equipment,
16. Biological safety,
17. Radiation safety.

Ordering Chemicals

Before purchasing a chemical, prudent laboratory personnel ask several questions:

- Is the material already available from another laboratory within the institution or from a surplus chemical stockroom? If so, waste is reduced, and the purchase price is saved. The tendency to use only new chemicals because of their purity should be scrutinized, and that tendency should be carefully justified to ensure that materials already on hand are used whenever possible.
- What is the maximum size container allowed in the areas where the material will be used and stored? Fire codes and institutional policies regulate quantities of certain chemicals, most notably flammables and combustibles. For these materials, a maximum allowable quantity for laboratory storage has been established.
- Can the chemical be managed safely when it arrives? Does it require special storage, such as in a drybox, refrigerator, or freezer? Do receiving personnel need to be notified of the order and given special instructions for receipt? Will any special equipment necessary to use the chemical be ready when it arrives? An effort should be made to order chemicals for just-in-time delivery by purchasing all unstable or extremely reactive materials from the same supplier with a request for one delivery at the best time for performing an experiment.
- Is the chemical unstable? Inherently unstable materials may have very short storage times and should be purchased just before use to avoid losing a reagent and creating an unnecessary waste of material and time. Some materials may require express or overnight delivery and will not tolerate being held in transit over a weekend or holiday.
- Can the waste be managed satisfactorily? A chemical that produces a new category of waste may cause problems for the waste management program. An appropriate waste characterization and method for proper disposal should be identified before the chemical is ordered.

Chemical Procurement

“Before a substance is received, information on proper handling, storage, and disposal should be known to those who will be involved.” The standard further states that “No container should be accepted without an adequate identifying label. Preferably, all substances should be received in a central location.” These procedures are strongly recommended. Personnel should be trained to identify signs of breakage (e.g., rattling) and leakage (e.g., wet spot or stain) on shipments and such shipments should be refused or opened in a hood by laboratory staff. Some organizations have specific purchasing policies to prohibit unauthorized purchases of chemicals and other hazardous materials. The purchaser must assume responsibility for ownership of the chemical. Because of the possibility of a chemical leak or release and subsequent exposure, chemical shipments should only be received by trained personnel in a laboratory or central receiving area with proper ventilation. Neither administrative offices nor the mail room is appropriate for receipt or opening of chemical shipments.

When preparing to order a chemical for an experiment, several questions should be asked:

- What is the minimum amount of this chemical that is needed to perform the experiment? Is it available elsewhere in the facility? Remember, when ordering chemicals, less is always best. Prudent purchasing methods will save storage space, money, and disposal costs. Larger containers require more storage space and will incur additional disposal costs if the chemical is not used.
- Has the purchase been reviewed to ensure that any special requirements can be met?
- Is the proper PPE available in the laboratory to handle this chemical?
- What are the special handling precautions?
- Where will the chemical be stored in the laboratory?
- Does the laboratory chemical hood provide proper ventilation?
- Are there special containment considerations in the event of a spill, fire, or flood?
- Will there be additional costs or considerations related to the disposal of this chemical?

Chemical Storage

To lessen risk of exposure to hazardous chemicals, trained laboratory personnel should separate and store all chemicals according to hazard category and compatibility. In the event of an accident involving a broken container or a chemical spill, incompatible chemicals that are stored in close proximity can mix to produce fires, hazardous fumes, and explosions. Laboratory personnel should read the MSDS and heed the precautions regarding the storage requirements of the chemicals in the laboratory. To avoid accidents, all chemical containers must be properly labeled with the full chemical name, not abbreviations, and using a permanent marker. All transfer vessels should have the following label information:

- Chemical name,
- Hazard warnings,
- name of manufacturer,
- name of researcher in charge, and
- date of transfer to the vessel.

Incoming chemical shipments should be dated promptly upon receipt, and chemical stock should be rotated to ensure use of older chemicals. It is good practice to date peroxide formers upon receipt and date again when the container is opened so that the user can dispose of the material according to the recommendations on the MSDS. Peroxide formers should be stored away from heat and light in sealed airtight containers with tight-fitting, nonmetal lids. Test regularly for peroxides and discard the material prior to the expiration date. When storing chemicals on open shelves, always use sturdy shelves that are secured to the wall and contain $\frac{3}{4}$ -in. lips. Do not store liquid chemicals higher than 5 ft on open shelves. Do not store chemicals within 18 in. of sprinkler heads in the laboratory. Use secondary containment devices (i.e., chemical-resistant trays) where appropriate. Do not store chemicals in the laboratory chemical hood, on the floor, in the aisles, in hallways, in areas of egress, or on the benchtop. Chemicals should be stored away from heat and direct sunlight. Only laboratory-grade explosion-proof refrigerators and freezers should be used to store properly sealed and labeled chemicals that require cool storage in the laboratory. Periodically clean and defrost the refrigerator and freezer to ensure maximum efficiency. Domestic refrigerators and freezers should not be used

to store chemicals; they possess ignition sources and can cause dangerous and costly laboratory fires and explosions. Do not store food or beverages in the laboratory refrigerator. Highly hazardous chemicals must be stored in a well-ventilated secure area that is designated for this purpose. Cyanides must be stored in a tightly closed container that is securely locked in a cool dry cabinet to which access is restricted. Protect cyanide containers against physical damage and separate them from incompatibles. When handling cyanides, follow good hygiene practices and regularly inspect your PPE. Use proper disposal techniques. Flammable liquids should be stored in approved flammable-liquid containers and storage cabinets. Observe National Fire Protection Association, International Building Code, International Fire Code, and other local code requirements that limit the quantity of flammables per cabinet, laboratory space, and building. Consult the local fire marshal for assistance, if needed. Store odiferous materials in ventilated cabinets. Chemical storage cabinets may be used for long-term storage of limited amounts of chemicals.

Chemical Inventory

“Stored chemicals should be examined periodically (at least annually) for replacement, deterioration, and container integrity. “Periodic inventories should be conducted, with unneeded items being discarded or returned to the storeroom/stockroom. On a basic level, you cannot safely manage something if you do not know that you have it on-site. Thus, a system for maintaining an accurate inventory of the laboratory chemicals on campus or within an organization is essential for compliance with local and state regulations and any building codes that apply. There are many benefits of performing annual physical chemical inventory updates:

- ensures that chemicals are stored according to compatibility tables,
- eliminates unneeded or outdated chemicals,
- increases ability to locate and share chemicals in emergency situations,
- updates the hazard warning signage on the laboratory door,
- promotes more efficient use of laboratory space,
- checks expiration dates of peroxide formers,
- ensures integrity of shelving and storage cabinets,
- encourages laboratory supervisors to make “executive decisions” about discarding dusty bottles of chemicals,
- repairs/replaces torn or missing labels and broken caps on bottles,
- ensures compliance with all federal, state, and local record-keeping regulations,
- promotes good relations and a sense of trust with the community and the emergency responders,
- reduces the risk of exposure to hazardous materials and ensures a clean and healthful laboratory environment, and
- may reduce costs by making staff aware of chemicals available within the organization.

Chemical Waste

All chemical waste must be stored and disposed of in compliance with applicable federal, state, local, and institutional regulatory requirements. Waste containers should be properly labeled and should be the minimum size that is required. There should be at least 2 in. of head space in the liquid waste container to avoid a buildup of gas that could cause an explosion or a container rupture.

Chemical Spill Policy

Laboratory personnel should be familiar with the chemical, physical, and toxicological properties of each hazardous substance in the laboratory. Always use the minimal amount of the chemical and use caution when transporting the chemical. In the event of an accidental chemical release or spill, personnel should refer to the following general guidelines. Most laboratory workers should be able to clean up incidental spills of the materials they use. Large spills, for example, 4 L or more, may require materials, protective equipment, and special handling that make it unsafe for cleanup by laboratory workers themselves. In the event that the spill material has been released to the environment, notify safety officer immediately. A release to the environment includes spills directly into a drain or waterway or onto land, such as grass or dirt.

Low-Flammability and Low-Toxicity Materials that are not Volatile (e.g., inorganic acids and caustic bases)

1. Decontaminate any victim at the nearest safety shower or eyewash unit.
2. Notify appropriate personnel immediately.
3. Limit or restrict access to the area as necessary.
4. Wear PPE that is appropriate to the degree of hazard of the spilled substance.
5. Use chemical spill kits that contain an inert absorbent to clean up the affected area if this action can be accomplished without risk of additional injury or contamination to personnel. If the spill is located on the laboratory floor, be aware that some absorbents can create a slipping hazard.
6. Dispose of contaminated materials according to institutional policy.
7. Complete an incident report and submit it to the appropriate office or individual.

Flammable Solvents of Low Toxicity (e.g., diethyl ether and tetrahydrofuran)

1. Decontaminate any victims at the nearest safety shower or eyewash unit.
2. Alert all other personnel in the laboratory and the general vicinity of the spill.
3. Extinguish all flames and turn off any spark-producing equipment. If necessary, turn off power to the laboratory at the circuit breaker. The ventilation system must remain operational.
4. Immediately notify appropriate personnel. The person to notify in case of an incident in the laboratory varies by organization. It may be the safety director, on-site security, or another party. Check with the organization to determine the appropriate individual or office.
5. Limit or restrict access to the area as necessary.
6. Wear PPE that is appropriate to the degree of hazard of the spilled substance.

7. Use spill pillows or spill absorbent and non-sparking tools to soak up the solvent as quickly as possible. Be sure to soak up chemicals that have seeped under equipment and other objects in the laboratory. If the spill is located on the laboratory floor, be aware that some absorbents can create a slipping hazard.
8. Dispose of contaminated materials according to institutional policy.
9. Complete an incident report and submit it to the appropriate office or individual.

Highly Toxic Materials (e.g., dimethylmercury)

1. Alert all trained laboratory personnel in the laboratory and the general vicinity of the spill and immediately evacuate the area.
2. Decontaminate any victims at a safety shower or eyewash unit in a safe location.
3. Immediately notify appropriate personnel.
4. Limit or restrict access to the area as necessary.
5. Do not attempt to clean up the spill.
6. Only appropriate outside industrial hygienists are authorized to decontaminate the area and dispose of the contaminated waste.
7. Complete an incident report and submit it to the appropriate office or individual.

Closing the Door on Lab Safety Hazards

Most of us think of lab doors as simply workplace entrances and exits. They are also very important to LIFE SAFETY and HAZARD CONTROL. There is a natural tendency to prop open lab doors when walking frequently between rooms. This practice may be more convenient, but it also compromises the safety of the laboratory and surrounding areas.

Consider this:

- Closed lab doors help contain chemical vapors and odors within the workplace and facilitate their efficient removal by the ventilation system! Most labs are designed to be at negative pressure – air flows from the corridor into the lab and is exhausted outside. This design is based on the lab door being closed. With the door open, the air balance between the lab and the corridor is easily defeated, this allows hazardous (or at least malodorous) chemical vapors to concentrate in the lab and escape into the hallways.
- By keeping doors open the fire safety of the corridors are negated. Certain exit access corridors are separated from other parts of the building by walls having a 1-hour fire resistance rating. Laboratory doors that open into a corridor must have a minimum 20-minute fire protection rating. A propped open door compromises the protection that these special walls provide to workers escaping the building in a fire.
- It is very important not to obstruct lab doors as they are your route to safety in an emergency! Since doors obviously serve as an exit from the lab space, it is important not to place obstructions near them so personnel can quickly exit in an emergency. Even in modular labs where there may be more than one door, a good policy is to ensure that at least two exits are readily accessible and not blocked.
- Don't block lab door window panes with paper, lab coats, or other items. The window provides for your safety and security. The ability of emergency and security personnel to see

into the laboratory is necessary to identify, notify, and assist individuals during emergency evacuations and to assist security personnel in locating people in need of emergency assistance, especially after normal working hours. For labs with locked doors in accordance with radiation safety, select agent, and other requirements, it is even more critical that the door windows not be blocked. Passersby who suspect a problem in a locked lab, even though they would not be able to enter, could see into the lab area and summon help if required.

Remember that when it comes to laboratory safety, keeping a CLOSED DOOR generally means keeping an open mind to SAFETY.

Disposal of Chemical Waste

- Do not dispose of chemical waste down the drain or with the regular garbage.
- Do not allow chemical waste to accumulate in the lab. Once a few liters (3 – 5 L) of waste have accumulated, have it transported for removal using portable waste safety cans or carriers.
- Clearly identify the contents of any container of waste.
- If in doubt as to correct disposal procedures, contact the Laboratory Supervisor for Advice

Flammable Liquids

- Place waste solvent in approved waste solvent disposal cans with the flame arresters in good condition.
- Do not over fill these cans.
- Do not remove the flame arresters.

Acids and Alkali

- Dilute small volumes of acids and alkalis before disposal down the drain.
- Collect large volumes of acids or alkalis in labeled plastic bottles.

Disinfection and Sterilization

A basic knowledge of disinfection and sterilization is crucial for biosafety in the laboratory. Since heavily soiled items cannot promptly be disinfected or sterilized, it is equally important to understand the fundamentals of cleaning prior to disinfection (pre cleaning). In this regard, the following general principles apply to all known classes of microbial pathogens. Specific decontamination requirements will depend on the type of experimental work and the nature of the infectious agent(s) being handled. The generic information given here can be used to develop both standardized and more specific procedures to deal with biohazard(s) involved in a particular laboratory. Contact times for disinfectants are specific for each material and manufacturer. Therefore, all recommendations for use of disinfectants should follow manufacturers' specifications.

Definitions

Many different terms are used for disinfection and sterilization. The following are among the more common in biosafety:

Antimicrobial – An agent that kills microorganisms or suppresses their growth and multiplication.

Antiseptic – A substance that inhibits the growth and development of microorganisms without necessarily killing them. Antiseptics are usually applied to body surfaces.

Biocide – A general term for any agent that kills organisms.

Chemical germicide – A chemical or a mixture of chemicals used to kill microorganisms.

Decontamination – Any process for removing and/or killing microorganisms. The same term is also used for removing or neutralizing hazardous chemicals and radioactive materials.

Disinfectant – A chemical or mixture of chemicals used to kill microorganisms, but not necessarily spores. Disinfectants are usually applied to inanimate surfaces or objects.

Disinfection – A physical or chemical means of killing microorganisms, but not necessarily spores.

Microbicide – A chemical or mixture of chemicals that kills microorganisms. The term is often used in place of “biocide”, “chemical germicide” or “antimicrobial”. **Sporocide** – A chemical or mixture of chemicals used to kill microorganisms and spores.

Sterilization – A process that kills and/or removes all classes of microorganisms and spores.

Cleaning Laboratory Materials

Cleaning is the removal of dirt, organic matter and stains. Cleaning includes brushing, vacuuming, dry dusting, washing or damp mopping with water containing a soap or detergent. Dirt, soil and organic matter can shield microorganisms and can interfere with the killing action of decontaminants (antiseptics, chemical germicides and disinfectants). Pre cleaning is essential to achieve proper disinfection or sterilization. Many germicidal products claim activity only on pre cleaned items. Pre cleaning must be carried out with care to avoid exposure to infectious agents. Materials chemically compatible with the germicides to be applied later must be used. It is quite common to use the same chemical germicide for pre cleaning and disinfection.

Chemical Germicides

Many types of chemicals can be used as disinfectants and/or antiseptics. As there is an ever-increasing number and variety of commercial products, formulations must be carefully selected for specific needs.

The germicidal activity of many chemicals is faster and better at higher temperatures.

At the same time, higher temperatures can accelerate their evaporation and also degrade them. Particular care is needed in the use and storage of such chemicals in tropical regions, where their shelf-life may be reduced because of high ambient temperatures.

Many germicides can be harmful to humans or the environment. They should be selected, stored, handled, used and disposed of with care, following manufacturers' instructions. For personal safety, gloves, aprons and eye protection are recommended when preparing dilutions

of chemical germicides. Chemical germicides are generally not required for regular cleaning of floors, walls, equipment and furniture. However, their use may be appropriate in certain cases of outbreak control.

Proper use of chemical germicides will contribute to workplace safety while reducing the risk from infectious agents. As far as possible, the number of germicidal chemicals to be used should be limited for economic reasons, inventory control and to limit environmental pollution. Commonly used classes of chemical germicides are described below, with generic information on their applications and safety profiles. Unless otherwise indicated, the germicide concentrations are given in weight/volume (w/v). Table 7 summarizes the recommended dilutions of chlorine-releasing compounds.

Chlorine (sodium hypochlorite)

Chlorine, a fast-acting oxidant, is a widely available and broad-spectrum chemical germicide. It is normally sold as bleach, an aqueous solution of sodium hypochlorite (NaOCl), which can be diluted with water to provide various concentrations of available chlorine. Chlorine, especially as bleach, is highly alkaline and can be corrosive to metal. Its activity is considerably reduced by organic matter (protein). Storage of stock or working solutions of bleach in open containers, particularly at high temperatures, releases chlorine gas thus weakening their germicidal potential. The frequency with which working solutions of bleach should be changed depends on their starting strength, the type (e.g. with or without a lid) and size of their containers, the frequency and nature of use, and ambient conditions. As a general guide, solutions receiving materials with high levels of organic matter several times a day should be changed at least daily, while those with less frequent use may last for as long as a week. A general all-purpose laboratory disinfectant should have a concentration of 1 g/l available chlorine. A stronger solution, containing 5 g/l available chlorine, is recommended for dealing with biohazardous spillage and in the presence of large amounts of organic matter. Sodium hypochlorite solutions, as domestic bleach, contain 50 g/l available chlorine and should therefore be diluted 1:50 or 1:10 to obtain final concentrations of 1 g/l and 5 g/l, respectively. Industrial solutions of bleach have a sodium hypochlorite concentration of nearly 120 g/l and must be diluted accordingly to obtain the levels indicated above. Granules or tablets of calcium hypochlorite ($\text{Ca}(\text{ClO})_2$) generally contain about 70% available chlorine. Solutions prepared with granules or tablets, containing 1.4 g/l and 7.0 g/l, will then contain 1.0 g/l and 5 g/l available chlorine, respectively. Bleach is not recommended as an antiseptic, but may be used as a general-purpose.

Table 7. Recommended dilutions of chlorine-releasing compounds

	“CLEAN” CONDITIONS ^a	“DIRTY” CONDITIONS ^b
Available chlorine required	0.1% (1 g/l)	0.5% (5 g/l)
Sodium hypochlorite solution (5% available chlorine)	20 ml/l	100 ml/l
Calcium hypochlorite (70% available chlorine)	1.4 g/l	7.0 g/l
Sodium dichloroisocyanurate powder (60% available chlorine)	1.7 g/l	8.5 g/l
Sodium dichloroisocyanurate tablets (1.5 g available chlorine per tablet)	1 tablet per liter	4 tablets per liter
Chloramine (25% available chlorine)^c	20 g/l	20 g/l

a After removal of bulk material.

b For flooding, e.g. on blood or before removal of bulk material.

c See text.

Disinfectant and for soaking contaminated metal-free materials. In emergencies, bleach can also be used to disinfect water for drinking, with a final concentration of 1–2 mg/l available chlorine. Chlorine gas is highly toxic. Bleach must therefore be stored and used in well-ventilated areas only. Also, bleach must not be mixed with acids to prevent the rapid release of chlorine gas. Many by-products of chlorine can be harmful to humans and the environment, so that indiscriminate use of chlorine-based disinfectants, in particular bleach, should be avoided.

Sodium dichloroisocyanurate

Sodium dichloroisocyanurate (NaDCC) in powder form contains 60% available chlorine. Solutions prepared with NaDCC powder at 1.7 g/l and 8.5 g/l will contain 1 g/l or 5 g/l available chlorine, respectively. Tablets of NaDCC generally contain the equivalent of 1.5 g available chlorine per tablet. One or four tablets dissolved in 1 l of water will give approximately the required concentrations of 1 g/l or 5 g/l, respectively. NaDCC as powder or tablets is easy and safe to store. Solid NaDCC can be applied on spills of blood or other biohazardous liquids and left for at least 10 min before removal. Further cleaning of the affected area can then take place.

Chloramines

Chloramines are available as powders containing about 25% available chlorine. Chloramines release chlorine at a slower rate than hypochlorites. Higher initial concentrations are therefore required for efficiencies equivalent to those of hypochlorites. On the other hand, chloramine solutions are not inactivated by organic matter to the same extent as hypochlorite solutions, and concentrations of 20 g/l are recommended for both “clean” and “dirty” situations.

Chloramine solutions are virtually odour-free. However, items soaked in them must be thoroughly rinsed to remove any residue of the bulking agents added to chloramine-T (sodium tosylchloramide) powders.

Chlorine dioxide

Chlorine dioxide (ClO_2) is a strong and fast-acting germicide, disinfectant agent and oxidizer, often reported to be active at concentrations levels lower than those needed by chlorine as bleach. Chlorine dioxide is unstable as a gas and will undergo decomposition into chlorine gas (Cl_2), oxygen gas (O_2), giving off heat. However, chlorine dioxide is soluble in water and stable in an aqueous solution. Chlorine dioxide can be obtained in two ways: (1) on-site generation by mixing of two separate components, hydrochloric acid (HCl) and sodium chlorite (NaClO_2); and (2) ordering its stabilized form, which is then activated on-site when required. Of the oxidizing biocides, chlorine dioxide is the most selective oxidant. Ozone and chlorine are much more reactive than chlorine dioxide, and they will be consumed by most organic compounds. Chlorine dioxide, however, reacts only with reduced sulfur compounds, secondary and tertiary amines, and some other highly reduced and reactive organic compounds. A more stable residue can therefore be achieved with chlorine dioxide at much lower doses than when using either chlorine or ozone. Generated properly, chlorine dioxide can be used more effectively than ozone or chlorine in cases of higher organic loading because of its selectivity.

Formaldehyde

Formaldehyde (HCHO) is a gas that kills all microorganisms and spores at temperatures above 20°C . However, it is not active against prions. Formaldehyde is relatively slow-acting and needs a relative humidity level of about 70%. It is marketed as the solid polymer, paraformaldehyde, in flakes or tablets, or as formalin, a solution of the gas in water of about 370 g/l (37%), containing methanol (100 ml/l) as a stabilizer. Both formulations are heated to liberate the gas, which is used for decontamination and disinfection of enclosed volumes such as safety cabinets and rooms (see section on Local environmental decontamination in this chapter). Formaldehyde (5% formalin in water) may be used as a liquid disinfectant. Formaldehyde is a suspected carcinogen. It is a dangerous, irritant gas that has a pungent smell and its fumes can irritate eyes and mucous membranes. It must therefore be stored and used in a fume-hood or well-ventilated area. National chemical safety regulations must be followed.

Glutaraldehyde

Like formaldehyde, glutaraldehyde ($\text{OHC}(\text{CH}_2)_3\text{CHO}$) is also active against vegetative bacteria, spores, fungi and lipid- and nonlipid-containing viruses. It is non-corrosive and faster acting than formaldehyde. However, it takes several hours to kill bacterial spores. Glutaraldehyde is generally supplied as a solution with a concentration of about 20 g/l (2%) and some products may need to be “activated” (made alkaline) before use by the addition of a bicarbonate compound supplied with the product. The activated solution can be reused for 1–4 weeks depending on the formulation and type and frequency of its use. Dipsticks supplied with some products give only a rough indication of the levels of active glutaraldehyde available in solutions

under use. Glutaraldehyde solutions should be discarded if they become turbid. Glutaraldehyde is toxic and an irritant to skin and mucous membranes, and contact with it must be avoided. It must be used in a fume-hood or in well-ventilated areas. It is not recommended as a spray or solution for the decontamination of environmental surfaces. National chemical safety regulations must be followed.

Phenolic compounds

Phenolic compounds, a broad group of agents, were among the earliest germicides. However, more recent safety concerns restrict their use. They are active against vegetative bacteria and lipid-containing viruses and, when properly formulated, also show activity against mycobacteria. They are not active against spores and their activity against nonlipid viruses is variable. Many phenolic products are used for the decontamination of environmental surfaces, and some (e.g. triclosan and chloroxylenol) are among the more commonly used antiseptics. Triclosan is common in products for hand-washing. It is active mainly against vegetative bacteria and safe for skin and mucous membranes. However, in laboratorybased studies, bacteria made resistant to low concentrations of triclosan also show resistance to certain types of antibiotics. The significance of this finding in the field remains unknown. Some phenolic compounds are sensitive to and may be inactivated by water hardness and therefore must be diluted with distilled or deionized water. Phenolic compounds are not recommended for use on food contact surfaces and in areas with young children. They may be absorbed by rubber and can also penetrate the skin. National chemical safety regulations must be followed.

Quaternary ammonium Compounds

Many types of quaternary ammonium compounds are used as mixtures and often in combination with other germicides, such as alcohols. They have good activity against some vegetative bacteria and lipid-containing viruses. Certain types (e.g. benzalkonium chloride) are used as antiseptics. The germicidal activity of certain types of quaternary ammonium compounds is considerably reduced by organic matter, water hardness and anionic detergents. Care is therefore needed in selecting agents for precleaning when quaternary ammonium compounds are to be used for disinfection. Potentially harmful bacteria can grow in quaternary ammonium compound solutions. Owing to low biodegradability, these compounds may also accumulate in the environment.

Alcohols

Ethanol (ethyl alcohol, C_2H_5OH) and 2-propanol (isopropyl alcohol, $(CH_3)_2CHOH$) have similar disinfectant properties. They are active against vegetative bacteria, fungi and lipid-containing viruses but not against spores. Their action on non-lipid viruses is variable. For highest effectiveness they should be used at concentrations of approximately 70% (v/v) in water: higher or lower concentrations may not be as germicidal. A major advantage of aqueous solutions of alcohols is that they do not leave any residue on treated items. Mixtures with other agents are more effective than alcohol alone, e.g. 70% (v/v) alcohol with 100 g/l formaldehyde, and alcohol containing 2 g/l available chlorine. A 70% (v/v) aqueous solution of ethanol can be

used on skin, work surfaces of laboratory benches and biosafety cabinets, and to soak small pieces of surgical instruments. Since ethanol can dry the skin, it is often mixed with emollients. Alcohol-based hand-rubs are recommended for the decontamination of lightly soiled hands in situations where proper hand-washing is inconvenient or not possible. However, it must be remembered that ethanol is ineffective against spores and may not kill all types of nonlipid viruses. Alcohols are volatile and flammable and must not be used near open flames. Working solutions should be stored in proper containers to avoid the evaporation of alcohols. Alcohols may harden rubber and dissolve certain types of glue. Proper inventory and storage of ethanol in the laboratory is very important to avoid its use for purposes other than disinfection. Bottles with alcohol-containing solutions must be clearly labelled to avoid autoclaving.

Iodine and Iodophors

The action of these disinfectants is similar to that of chlorine, although they may be slightly less inhibited by organic matter. Iodine can stain fabrics and environmental surfaces and is generally unsuitable for use as a disinfectant. On the other hand, iodophors and tinctures of iodine are good antiseptics. Polyvidone-iodine is a reliable and safe surgical scrub and preoperative skin antiseptic. Antiseptics based on iodine are generally unsuitable for use on medical/dental devices. Iodine should not be used on aluminium or copper. Iodine can be toxic. Organic iodine-based products must be stored at 4–10 °C to avoid the growth of potentially harmful bacteria in them.

Hydrogen peroxide and Peracids

Like chlorine, hydrogen peroxide (H_2O_2) and peracids are strong oxidants and can be potent broad-spectrum germicides. They are also safer than chlorine to humans and the environment. Hydrogen peroxide is supplied either as a ready-to-use 3% solution or as a 30% aqueous solution to be diluted to 5–10 times its volume with sterilized water. However, such 3–6% solutions of hydrogen peroxide alone are relatively slow and limited as germicides. Products now available have other ingredients to stabilize the hydrogen peroxide content, to accelerate its germicidal action and to make it less corrosive. Hydrogen peroxide can be used for the decontamination of work surfaces of laboratory benches and biosafety cabinets, and stronger solutions may be suitable for disinfecting heat-sensitive medical/dental devices. The use of vaporized hydrogen peroxide or peracetic acid (CH_3COOOH) for the decontamination of heat-sensitive medical/surgical devices requires specialized equipment. Hydrogen peroxide and peracids can be corrosive to metals such as aluminium, copper, brass and zinc, and can also decolorize fabrics, hair, skin and mucous membranes. Articles treated with them must be thoroughly rinsed before contact with eyes and mucous membranes. They should always be stored away from heat and protected from light.

Local Environmental Decontamination

Decontamination of the laboratory space, its furniture and its equipment requires a combination of liquid and gaseous disinfectants. Surfaces can be decontaminated using a solution of sodium hypochlorite (NaOCl); a solution containing 1 g/l available chlorine may be suitable for general environmental sanitation, but stronger solutions (5 g/l) are recommended when dealing with high-risk situations. For environmental decontamination, formulated solutions containing 3% hydrogen peroxide (H₂O₂) make suitable substitutes for bleach solutions.

Rooms and equipment can be decontaminated by fumigation with formaldehyde gas generated by heating paraformaldehyde or boiling formalin. This is a highly dangerous process that requires specially trained personnel. All openings in the room (i.e. windows, doors, etc.) should be sealed with masking tape or similar before the gas is generated. Fumigation should be conducted at an ambient temperature of at least 21 °C and a relative humidity of 70%.

After fumigation the area must be ventilated thoroughly before personnel are allowed to enter. Appropriate respirators must be worn by anyone entering the room before it has been ventilated. Gaseous ammonium bicarbonate can be used to neutralize the formaldehyde. Fumigation of smaller spaces with hydrogen peroxide vapor is also effective but requires specialized equipment to generate the vapor.

Decontamination of Biological Safety Cabinets

To decontaminate Class I and Class II cabinets, equipment that independently generates, circulates and neutralizes formaldehyde gas is available. Alternatively, the appropriate amount of paraformaldehyde (final concentration of 0.8% paraformaldehyde in air) should be placed in a frying pan on an electric hot plate. Another frying pan, containing 10% more ammonium bicarbonate than paraformaldehyde, on a second hot plate is also placed inside the cabinet. The hot plate leads are plugged in outside the cabinet, so that operation of the pans can be controlled from the outside by plugging and unplugging the hot plates as necessary. If the relative humidity is below 70%, an open container of hot water should also be placed inside the cabinet before the front closure is sealed in place with strong tape (e.g. duct tape). Heavy gauge plastic sheeting is taped over the front opening and exhaust port to make sure that the gas cannot seep into the room. Penetration of the electric leads passing through the front closure must also be sealed with duct tape.

The plate for the paraformaldehyde pan is plugged in. It is unplugged when all the paraformaldehyde has vaporized. The cabinet is left undisturbed for at least 6 h. The plate for the second pan is then plugged in and the ammonium bicarbonate is allowed to vaporize. This plate is then unplugged and the cabinet blower is switched on for two intervals of approximately 2 s each to allow the ammonium bicarbonate gas to circulate. The cabinet should be left undisturbed for 30 min before the front closure (or plastic sheeting) and the exhaust port sheeting are removed. The cabinet surfaces should be wiped down to remove residues before use.

Disposal of Biological Waste

Place all biological waste (discarded biological specimens, culture media etc.) into double yellow plastic biohazard bags.

Place glass tubes, blood culture bottles etc. into double yellow biohazard bags in designated cardboard boxes that are sealed once filled. Do not overfill. Blood culture boxes should only be half full.

Place all contaminated sharp objects (sharp pipettes, disposable plastic pipette tips, needles, broken glass, etc.) into a designated puncture resistant biohazard sharps container. Do not shear, bend, break or recap needles. Place full biohazard sharps containers into the large plastic collection bin located in the wash-up/sterilization room.

On weekday mornings the biological waste is collected from all around the microbiology laboratory by designated microbiology personnel. On weekday evenings housekeeping comes and picks up the large plastic collection bin located in the washup/ sterilization room. The bins of waste are transported to MSH elevator #3. This elevator has been designated for waste removal. Designated housekeeping personnel then transport the waste down the elevator to the shipping area. The biological waste is picked up by Medical Management Incorporated for autoclaving prior to being sent to a landfill site. Pickup occurs twice a day on weekdays, and once a day on weekends. Fluid effluent etc. may be disposed of directly into a sanitary sewer line or into a lab sink (NOT a hand-wash sink).

Disposal of Chemical Waste

General Procedures

- Do not dispose of chemical waste down the drain or with the regular garbage.
- Do not allow chemical waste to accumulate in the lab. Once a few liters (3 – 5 L) of waste have accumulated, have it transported for removal using portable waste safety cans or carriers.
- Clearly identify the contents of any container of waste.
- If in doubt as to correct disposal procedures, contact the Laboratory Supervisor for advice.
- **Flammable Liquids**
 - ✓ Place waste solvent in approved waste solvent disposal cans with the flame arresters in good condition.
 - ✓ Do not over fill these cans.
 - ✓ Do not remove the flame arresters.
- **Acids and Alkali**
 - ✓ Dilute small volumes of acids and alkalis before disposal down the drain.
 - ✓ Collect large volumes of acids or alkalis in labeled plastic bottles.

Electrical and Mechanical Safety

- 1. Grounding:** All instruments must be grounded including household type appliances, coffee pots, etc. The only exceptions to the rule are items entirely encased in plastic (such as microscopes).
- 2. Report shocks:** All shocks must be reported immediately, including small tingles. Small shocks often precede major shocks and a light tingle may indicate potential trouble. Notify supervisory personnel of any shocks.
- 3. Corrective actions:** Shut off the current and/or unplug the instrument. Do not attempt to use an instrument that is causing shocks. Not only is it potentially dangerous, but also any results from the instrument would be suspect.
- 4. Repairs:** DO NOT work on or attempt to repair any instrument while it is plugged in. An exception is the calibration of instruments that require adjustment while plugged in. In this case, be sure hands are dry, remove all jewelry (watches and rings) and proceed with caution.
- 5. Repairs on the electrical system of the building are prohibited.** Any work performed on switches, outlets or circuit boxes (fuses, circuit breaker) must be referred to the building maintenance personnel.
- 6. Extension cords should be avoided.** If used, they must be the 3-way type and properly grounded. Gang plugs are prohibited.
- 7. New equipment using electrical power should be checked for absence of chassis leaks and other safety hazards by a Biomedical Engineering Technician.**
- 8. Major pieces of equipment may be included in the Clinical Engineering Department's "High-Technology Equipment" program, and will be identified as such by a yellow metal tag.** Records concerning initial specifications and safety checks are in their system.
- 9. For a more explicit procedure and protocol, consult the JHH Safety Manual.**

Compressed Gases

Introduction: Compressed gases constitute several hazards. Any gas cylinder with a broken valve head becomes a missile capable of penetrating walls. Specific gases may be toxic or flammable. In addition, heating of cylinders may result in explosion.

General Standards:

- a.** All compressed gas cylinders shall be secured in an upright position by means of a strap, chain or non-tip base. This includes cylinders either in use or in storage (empty or full).
- b.** Suitable hand trucks will be utilized when transporting gas cylinders.
- c.** Protective valve caps must be in place when cylinders are not in use.
- d.** All cylinders, lines, and equipment used with flammable compressed gases shall be grounded.
- e.** When in use, all cylinders must be equipped with an appropriate regulating device. All regulators must be marked to identify the gas (or group of compatible gases) with which the regulator is to be used. Regular threads must match cylinder valve outlet threads.

- f. When a cylinder is in use, a hand wheel, valve handle, spindle key or special tool to activate the cylinder valve shall be attached to the cylinder so that it will immediately be available in the event of an emergency.
- g. Cylinders containing compressed gases shall be used only in well-ventilated areas.
- h. Cylinders containing toxic or flammable gases must be stored in an approved storage area. The use of the smallest possible cylinder of toxic or flammable gases is recommended.
- i. Cylinders containing oxidizing gases, such as oxygen and nitrous oxide, shall be stored separately from flammable gases or liquids.
- j. Empty cylinders shall be so identified and stored separately from full or partially full cylinders.
- k. Compressed gas cylinders shall be used only for their intended purposes.
- l. Cylinders must not be stored with or near flammable materials.
- m. Do not use oil, grease or lubricants on valves, regulators or fittings.
- n. Do not attempt to repair damaged cylinders or to force frozen cylinder valves.

Flammable gasses: Special care must be used when gases are used in confined spaces

- a. No more than two cylinders should be manifolded together; however, several instruments or outlets are permitted for a single cylinder.
- b. No more than one cylinder of highly flammable gas shall be in one room without specific review by the Director (or Safety Officer).
- c. Standby cylinders (full or empty) must not be stored in the lab
- d. Cylinder size is limited to 200 cubic feet. Valves on all flammable gas cylinders shall be shut off when the laboratory is unattended.

Pressure regulators and needle valves:

Needle valves and regulators are designed specifically for different families of gases. Use only the properly designated fittings.

- a. Threads and surfaces must be clean and tightly fitted. Do not lubricate.
- b. Tighten regulators and valves firmly with the proper sized wrench. (Do not use adjustable wrenches or pliers. They damage the nuts.) Do not force tight fits.
- c. Open valves slowly. Do not stand directly in front of gauges (the gauge face may blow out). Do not force valves that "stick".
- d. Check for leaks at connections. Leaks are usually due to damaged faces at connections or improper fittings. Do not attempt to force an improper fit. (It may only damage a previously undamaged connection and compound the problem.)
- e. Valve handles must be left attached to the cylinders.
- f. The maximum rate of flow should be set by the high pressure valve on the cylinder. Fine tuning of flow should be regulated by the needle valve.
- g. Shut off cylinders when not in use.

Leak Testing:

Cylinders and connections should be tested by "snoop" or a soap solution. First, test the cylinders before regulators are attached, and then test again after the regulators or gauges are attached.

Empty Cylinders:

- a. Must be marked empty, and remain secured in an upright position with safety cap in place.

Ultraviolet Light Decontamination

Under certain conditions of radiation intensity, exposure time, humidity, and temperature, ultraviolet radiation at approximately 254 nanometers will cause eventual death of microorganisms. The radiation at this wavelength causes formation of thymine-thymine dimers and other effects on DNA and RNA.

Nucleic acid containing thymine dimers does not replicate properly and lethal mutations are often produced. Ultraviolet light's greatest effectiveness is against actively growing bacteria. Low pressure mercury vapor lamps usually supplied with biological safety cabinets emit germicidal radiation at a wavelength of 254 nanometers for about nine months. After this time, the lamp may not produce enough germicidal radiation to effectively kill bacteria, even though it appears to be functioning properly. In general, ultraviolet radiation is used to reduce exogenous contaminants and/or pathogenic microorganisms on exposed surfaces and in the air.

UV Lamp Operation

1. All UV installations used for disinfecting should be checked semiannually. Periodic examination is necessary because UV bulbs may continue to burn without emitting effective radiation. UV lamps should be replaced when they emit 70 percent or less of their rated initial output.
2. UV lamps installed in biological safety cabinets must be replaced when the 254 nm UV irradiation intensity on the work tray surface of the cabinet is less than 40 microwatts per square centimeter.
3. UV lamps should be cleaned often if located in an unusually dusty area. Lamps should be turned off and wiped with a soft pad moistened with alcohol. Cleansing is the responsibility of the personnel in charge of the laboratory.
4. All exposed UV installations in lighting fixtures and safety cabinets shall be turned on only when no personnel are in the area. Louvered, wall mounted UV equipment may be left on continuously.
5. Each UV installation should be equipped with an outside switch and an appropriate safety sign. Interlocks should be installed where appropriate to turn off UV lamps when room lights are turned on.
6. Biological safety cabinets listed by the National Sanitation Foundation (NSF) after 1992 may not have UV lamps installed because there is no longer a NSF secondary test standard for UV lamps. Annual testing is required at JHMI, however, for Biological Safety Cabinets containing UV lamps.

Training

All personnel should be instructed in the proper use of each UV installation. Such instruction should include emphasis on the following:

1. Do not look directly at UV lamps;
2. Do not loiter in UV airlocks and door barriers;
3. Turn off lamps before cleaning;
4. Wear eye and skin protection if anticipated exposure to UV will be for longer than a few seconds;
5. Protective goggles should transmit less than 4% of 400 nm wavelength light;
6. Particular care needs to be exercised around UV gel transilluminators, as they produce considerable radiation.

Emergency Shower and Eyewash Installation, Use, Testing and Maintenance Policy

PURPOSE: To identify areas that require emergency showers and eyewashes, and to provide procedures on proper use, testing and maintenance.

Procedure

Responsibility

Department of Environmental Health & Safety

- a. Determine areas that require emergency showers and eyewash stations.
- b. Provide the specification for the type of emergency showers and eyewash stations.
- c. Provide proper installation, maintenance and testing criteria.

Campus Operations & Maintenance

- a. Test all emergency showers and eyewash stations annually for compliance.
- b. Make any and all necessary repairs to emergency showers and eyewash stations so that they operate according to the current standards and regulations. If the equipment cannot be repaired, safety officer must replace the existing equipment with new equipment.
- c. Maintain records of all testing results and repairs.

Departments

- a. Departments must ensure that all staff are instructed in the location, use and limitations of the emergency showers and eyewash stations.
- b. Department staff must test eyewash stations weekly. Records of test will be maintained by the Department.
- c. Department staff must inspect personal wash units (eyewash bottles) weekly for expiration date.
- d. The Department must contact safety officer if the emergency shower and/or eyewash station are not working properly and need repair.
- f. Departments must purchase and install any new emergency showers and/or eyewash

stations that may be required due to changes in work or requirements.

g. Prior to purchasing this equipment, the Department must confirm with Environmental Health and Safety the type of equipment required.

Required Locations

Any area that uses corrosive materials, including but not limited to battery charging areas, and any laboratory using hazardous chemicals must have an emergency shower and eyewash plumbed to the building water supply lines. Hazardous chemicals that require a plumbed eyewash include: formaldehyde, methylene chloride, and any of the carcinogens : Asbestos, alpha-Naphthylamine, Methyl chloromethyl ether, 3,3'-Dichlorobenzidine (and its salts), bis-Chloromethyl ether, beta-Naphthylamine, Benzidine, 4-Aminodiphenyl, Ethyleneimine, beta-Propiolactone, 2-Acetylaminofluorene, 4- Dimethylaminoazobenzene, N-Nitrosodimethylamine, Vinyl chloride, Inorganic arsenic, Cadmium, Benzene, 1,2-dibromo-3-chloropropane, Acrylonitrile, Ethylene oxide, Methylenedianiline, 1,3-Butadiene, 4-Nitrobiphenyl, alpha-Naphthylamine, methyl chloromethyl ether, 3,3'-Dichlorobenzidine (and its salts), bis-Chloromethyl ether, beta- Naphthylamine, Benzidine, 4-Aminodiphenyl, Ethyleneimine, beta Propiolactone, 2- Acetylaminofluorene, 4-Dimethylaminoazo-benezene, and N Nitrosodimethylaminell.

New Equipment Installation Requirements

1. All emergency showers and eyewash station must be purchased and installed to comply with Standard for Emergency Eyewash and Shower Equipment.
2. All new equipment and replacement equipment must be approved and be acceptable.
3. All emergency showers and eyewash stations must remain “on” once activated without requiring further use of the operator’s hands until intentionally closed.
4. All new installations must deliver tepid flushing fluid (moderately warm or lukewarm potable water supply). Temperatures must not exceed 100°F and not be lower than 60°F.
5. All emergency showers and eyewash stations must be installed away from other hazards, such as but not limited to electrical outlets. If an electrical outlet is within 6 feet of the emergency shower or eyewash station, the outlet must be protected with a ground fault circuit interrupter. The eyewash station must be installed to provide enough room to allow the eyelids to be held open with the hands while the eyes are in the flushing fluid stream.

Use

1. All RCPN staff working in laboratories where hazardous chemicals are used, or are working with corrosive materials, formaldehyde, methylene chloride or a carcinogen, must be instructed on the location, proper use and limitations of emergency showers and eyewash stations.
2. Protective equipment (chemical splash goggles and lab coats) must be worn when working with hazardous chemicals as the first line of defense. Emergency showers and eyewash stations are not a substitute for proper primary protective devices.

- 3.** Staff must be instructed to flush contaminated eyes and body for a minimum of 15 minutes. The eyelids must be held open to allow for proper flushing. Remove all contaminated clothing, including shoes, while under the emergency shower. Another staff must contact Biosafety Office Personnel for emergency medical assistance. Anyone who becomes contaminated with hazardous chemicals and uses the emergency shower and/or eyewash station must receive medical attention at University Hospital Emergency Department or other healthcare provider.
- 4.** Personal eyewash bottles are not to be substituted for plumbed eyewash stations. These bottles do not provide enough water to flush contaminated eyes for 15 minutes. These bottles may be kept in the immediate vicinity of staff working in a potentially hazardous area to supply immediate flushing. After this initial flushing, the injured individual must then proceed to a plumbed eyewash and flush the eyes for the required 15 minute period.

Testing and Maintenance

- 1.** All emergency eyewash stations must be tested weekly by the user for a period long enough (at least 3 minutes) to verify operation, ensure that flushing fluid is available and to clear the supply line of any sediment build-up that could prevent fluid from being delivered to the head of the device and minimize microbial contamination due to sitting water. Testing is to be performed in a safe manner that will contain the water and not cause flooding. Any water on the floor must be immediately cleaned up.
if flooding occurs. After testing, replace the covers that protect the heads from dust and other airborne contaminants.
- 2.** All personal wash units (eyewash bottles), where permitted, must be checked weekly by the user for the expiration date and to determine if it has been used. Dispose of any opened or expired eyewash bottles.
- 3.** All emergency showers and eyewash stations must be inspected annually
- 4.** If any emergency shower or eyewash station is found to not work properly, the user must immediately contact for repair.

Essential Biosafety Equipment

- 1.** Pipetting aids:
 - To avoid mouth pipetting. Many different designs are available.
- 2.** Biological safety cabinets, to be used whenever:
 - Infectious materials are handled; such materials may be centrifuged in the open laboratory if sealed centrifuge safety cups are used and if they are loaded and unloaded in a biological safety cabinet
 - There is an increased risk of airborne infection
 - Procedures with a high potential for producing aerosols are used; these may include centrifugation, grinding, blending, vigorous shaking or mixing, sonic disruption, opening of containers of infectious materials whose internal pressure may be different from the ambient pressure, intranasal inoculation of animals, and harvesting of infectious tissues from animals and eggs.

3. Plastic disposable transfer loops. Alternatively, electric transfer loop incinerators may be used inside the biological safety cabinet to reduce aerosol production.
4. Screw-capped tubes and bottles.
5. Autoclaves or other appropriate means to decontaminate infectious materials.
6. Plastic disposable Pasteur pipettes, whenever available, to avoid glass.
7. Equipment such as autoclaves and biological safety cabinets must be validated with appropriate methods before being taken into use.

Eyewash Safety Training Handout

Eyewash Safety

Follow these guidelines to make sure that you will have working emergency eyewash available when you need it!

1. Make sure that everyone who works in the lab knows where the emergency eyewash and shower are located and how to use them.
2. In each lab, there should be eyewash provided at least 10 seconds from any researcher. Eyewash units should supply a multistream cross flow of potable water at 65° to 75°F (18.3°C to 23.8°C). Contaminated eyes should be flushed for 15 minutes. Eyewashes should flow at a rate of 3 to 7 gallons of water per minute.
3. Test the eyewash weekly by running the water for at least 3 minutes. This will ensure that there is sufficient water flow and no sediment build-up in the plumbing lines.
4. Check any eyewash bottles weekly for expiration date. Discard any opened bottles.
5. Contact ? if your eyewash is not working.
6. Always use protective eyewear when working with chemicals.
7. In case of a chemical splash to your eyes:
 - Hold your eyelids open with your hands and roll your eyes while using the eyewash to be sure water reaches the eyes and under your eyelids.
 - Keep your eyes in the water stream for 15 minutes.
 - Don't let contaminated water run into the non-contaminated eye.
 - Immediately wash off even small amounts of chemicals.
 - Get medical assistance immediately following flushing.
 - If possible, continue flushing while on way to medical help.
 - Know the effects of chemicals with which you are working. Read, ask questions about, and understand material safety data sheets for each chemical with which you work.
 - Know how to help others reach showers or eyewashes and how to help them get medical assistance.
 - Complete an Accident Report for all chemical contamination incidents.

*Use chemical splash goggles when working with corrosive liquids, chemicals with an “eye” hazard or a “SKIN” designation. Safety glasses are good for incidental exposures but will not protect from splashes. Use a face shield with chemical splash goggles under shield when pouring corrosives greater than 1 liter or filling/dispensing liquid nitrogen. Contact EH&S for more information on protective eyewear or other lab safety issues.

First Aid

The first-aid box should be constructed from materials that will keep the contents dust- and damp-free. It should be kept in a prominent position and be easily recognized.

By international convention, the first-aid box is identified by a white cross on a green background.

The first-aid box should contain:

1. Instruction sheet giving general guidance
2. Individually-wrapped sterile adhesive dressings in a variety of sizes
3. Sterile eye-pads with attachment bandages
4. Triangular bandages
5. Sterile wound coverings
6. Safety pins
7. A selection of sterile but unmedicated wound dressings
8. An authoritative first-aid manual, e.g. one issued by the International Red Cross.

Protective equipment for the person rendering first aid includes:

1. Mouthpiece for mouth-to-mouth resuscitation
2. Gloves and other barrier protections against blood exposures

Fire Safety in Labs

Close cooperation between safety officers and local fire prevention officers is essential. Apart from chemical hazards, the effects of fire on the possible dissemination of infectious material must be considered. This may determine whether it is best to extinguish or contain the fire.

The assistance of local fire prevention officers in the training of laboratory staff in fire prevention, immediate action in case of fire and the use of fire-fighting equipment is desirable. Fire warnings, instructions and escape routes should be displayed prominently in each room and in corridors and hallways. Common causes of fires in laboratories are:

1. Electrical circuit overloading
2. Poor electrical maintenance, e.g. poor and perished insulation on cables
3. Excessively long gas tubing or long electrical leads
4. Equipment unnecessarily left switched on
5. Equipment that was not designed for a laboratory environment
6. Open flames
7. Deteriorated gas tubing
8. Improper handling and storage of flammable or explosive materials
9. Improper segregation of incompatible chemicals
10. Sparking equipment near flammable substances and vapors
11. Improper or inadequate ventilation.

Fire-fighting equipment should be placed near room doors and at strategic points in corridors and hallways. This equipment may include hoses, buckets (of water or sand) and a fire

extinguisher. Fire extinguishers should be regularly inspected and maintained, and their shelf-life kept up to date. Specific types and uses of fire extinguishers are shown in Table 8.

Table 8. Types and uses of fire extinguishers

TYPE	USE FOR	DO NOT USE FOR
Water	Paper, wood, fabric	Electrical fires, flammable liquids, burning metals
Carbon dioxide (CO₂) extinguisher gases	Flammable liquids and gases, electrical fires	Alkali metals, paper
Dry powder	Flammable liquids and gases, alkali metals, electrical fires	Reusable equipment and instruments, as residues are very difficult to remove
Foam	Flammable liquids	Electrical fires

Flame Safety

Open flames present fire hazards. Bunsen Burners and other devices produce an open flame and burn at a high temperature (more than 2000 degrees F). Micro-touch burners are safer than Bunsen burners. There is always the potential for something to catch fire with any flame. Follow these guidelines to reduce the fire risk. In case of a fire, activate the nearest fire alarm pull station, notify all lab personnel, and evacuate the building.

- Place the burner away from any overhead shelving, equipment or light fixtures by at least 12 inches.
- Remove all papers, notebooks, combustible materials and excess chemicals from the area.
- Tie-back any long hair, dangling jewelry, or loose clothing.
- Only use tubing rated for gas. Don't use tygon tubing.
- Inspect hose for cracks, holes, pinch points or any defect. Replace all hoses found to have a defect before using. Ensure that the hose fits securely on the gas valve and the burner.
- Utilize a sparker/lighter with extended nozzle to ignite the burner. Never use a match to ignite a burner.
- Adjust the flame to regulate air flow and produce an appropriate flame for the experiment (typically a medium blue flame).
- Allow the burner to cool before handling.
- Ensure that the main gas valve is off before leaving the laboratory.

Shut off gas when done.

Do not leave open flames unattended.

Never leave the laboratory while the burner is on.

WARNING: Never fill or empty any torch or lighter over a sink (or similar well) or surface depression. Butane gas is heavier than air and may collect in low spaces, and ignite if sparked. Always refill your torch in a well ventilated room and always allow gas to stabilize for 60 seconds before attempting to ignite.

Fume Hood Work Practices and Procedures

1. Make sure your work area is clean and uncluttered before using a fume hood
2. Never use the fume hood to store chemicals and equipment between procedures.
3. Verify the date on the inspection sticker on the fume hood. The fume hood should be inspected annually. Contact Environmental Health and Safety for inspection.
4. The fume hood average face velocity should be between 100-150 feet per minute.
5. If the hood is not equipped with an air measuring device, verify adequate inward airflow by using smoke tubes, dry ice in a beaker or tissue paper.
6. Do not use the fume hood if it is not working properly.
7. Inspect the bypass area, airfoil, sash and access opening to verify that no air passages are blocked. Never remove the sash except during set up and no source of chemical exposure in the fume hood.
8. Never put your head inside a fume hood except during set up and no source of chemical exposure in the fume hood.
9. Electrical extension cords are not safe to use in a fume hood due to the danger of an explosion or fire.
10. Large equipment must be elevated on solid blocks to maintain an airflow space of 1-2 inches above the work surface.
11. Make sure equipment does not block the baffles at the rear of the hood.
12. Keep all apparatus at least 6 inches inside the fume hood. The best way to maintain this distance is to mark a safety line with tape.
13. Avoid opening and closing the sash rapidly, and avoid swift arm and body movements in front of or inside the hood. These actions may increase turbulence and reduce the effectiveness of the fume hood.
14. Position the sash so that it acts as a shield. Keep the sash as low as possible. The inspection sticker will indicate the maximum height. Always look through the sash, not under it.
15. If you observe defective or overheating equipment, shut off the equipment, disconnect it, close the sash, and report the problem to your supervisor.
16. Keep chemical containers closed at all times. Use condensers, traps, or scrubbers to contain and collect waste solvents, vapors or dusts.
17. Clean all spills immediately. Do not allow spilled liquid chemicals to evaporate.
18. If a fire occurs inside the fume hood, immediately close the sash and activate the fire alarm, exit the room, close the door and from a safe area, contact University Police to report a chemical fire.
19. Keep the fume hood exhaust on at all times.
20. Keep the sash closed completely when the fume hood is not in use.

Glove Safety

- All gloves should be inspected before and after each use, and periodically while in use. Check to ensure they are not torn, punctured, show signs of degradation, prior contamination or breakthrough.
- A visual inspection can detect cuts or tears.
- Test for pinholes by trapping air inside and rolling them out.
- Gloves that appear discolored or stiff may be subject to excessive use or degradation, and should be disposed.
- Follow the manufacturer's instructions for washing and caring for reusable gloves.
- If the integrity of the gloves is in question, replace immediately.
- Disposable gloves should be changed as soon as possible after contamination.
- Reusable gloves should be washed frequently if used for an extended period of time.
- Do not handle anything but the materials involved in the procedure while wearing gloves. Touching equipment, phones, wastebaskets or other surfaces may cause contamination. Be aware of touching the face, hair, and clothing as well.
- The outside surface of reusable gloves must be washed before removal and air-dried in the laboratory.
- To remove gloves without skin exposure, remove the first glove by grasping the cuff and peeling the glove off the hand so that the glove is inside out. Repeat this process with the second hand, touching the inside of the glove cuff, rather than the outside.
- Always wash your hands after removing gloves.

Gloves and Lab Coats

To Wear or Not To Wear?

A very important question for your safety!

Why Wearing Gloves is Important

It is important to wear gloves when working with hazardous chemicals and other materials because they protect our hands from infection and contamination. Protective gloves should be selected on the basis of the hazards involved.

- Nitrile gloves protect against most chemicals and infectious agents.
- Rubber gloves protect against mild corrosive material.
- Neoprene gloves protect against most solvents, oils, and mild corrosive materials.
- Avoid latex gloves as many people are allergic or develop allergies to this material.

When to Wear Gloves

Wear gloves when your hands may come into contact with:

- infectious materials
- radioactive materials
- chemicals

When Not to Wear Gloves

Don't wear gloves when touching common surfaces, such as telephones, computers, door knobs, and elevator buttons, or that may be touched without gloves by others.

Don't wear gloves outside of the lab. When transporting hazardous materials between labs, use secondary containers that can be carried without gloves. (Bring gloves and spill materials in case of an accident.)

Why Should We Wear Lab Coats?

- Lab coats are personal protective equipment and should be worn in the lab when working with chemicals and biological to protect the skin and clothing from splatter and spills.
- Appropriate lab coats should be fully buttoned with sleeves rolled down. They should also be fire-resistant.
- In case of an accident, it is much faster and easier to remove a lab coat than street clothes to minimize skin contact with hazardous materials

When to Wear Lab Coats

- Always wear lab coats when working with hazardous materials.

When Not to Wear Lab Coats

- Don't wear lab coats in public places, such as offices, lunch rooms, lounge areas, or elsewhere outside the laboratory, as they can transfer hazardous materials and contaminate these areas.
- Don't bring lab coats home because you may contaminate others in the household.
- Don't launder lab coats at home or with other clothing.

Heat Disinfection and Sterilization

Heat is the most common among the physical agents used for the decontamination of pathogens. "Dry" heat, which is totally non-corrosive, is used to process many items of laboratory ware which can withstand temperatures of 160 °C or higher for 2–4 h. Burning or incineration is also a form of dry heat. "Moist" heat is most effective when used in the form of autoclaving.

Boiling does not necessarily kill all microorganisms and/or pathogens, but it may be used as the minimum processing for disinfection where other methods (chemical disinfection or decontamination, autoclaving) are not applicable or available. Sterilized items must be handled and stored such that they remain uncontaminated until used.

Autoclaving

Saturated steam under pressure (autoclaving) is the most effective and reliable means of sterilizing laboratory materials. For most purposes, the following cycles will ensure sterilization of correctly loaded autoclaves:

1. 3 min holding time at 134 °C
2. 10 min holding time at 126 °C
3. 15 min holding time at 121 °C
4. 25 min holding time at 115 °C.

Examples of different autoclaves include the following:

Gravity displacement autoclaves. Steam enters the chamber under pressure and displaces the heavier air downwards and through the valve in the chamber drain, fitted with a HEPA filter.

Pre-vacuum autoclaves. These machines allow the removal of air from the chamber before steam is admitted. The exhaust air is evacuated through a valve fitted with a HEPA filter. At the end of the cycle, the steam is automatically exhausted. These autoclaves can operate at 134 °C and the sterilization cycle can therefore be reduced to 3 min. They are ideal for porous loads, but cannot be used to process liquids because of the vacuum.

Fuel-heated pressure cooker autoclaves: These should be used only if a gravity displacement autoclave is not available. They are loaded from the top and heated by gas, electricity or other types of fuels. Steam is generated by heating water in the base of the vessel, and air is displaced upwards through a relief vent. When all the air has been removed, the valve on the relief vent is closed and the heat reduced. The pressure and temperature rise until the safety valve operates at a preset level. This is the start of the holding time. At the end of the cycle the heat is turned off and the temperature allowed to fall to 80 °C or below before the lid is opened.

Loading Autoclaves

Materials should be loosely packed in the chamber for easy steam penetration and air removal. Bags should allow the steam to reach their contents.

Precautions in the Use of Autoclaves

The following rules can minimize the hazards inherent in operating pressurized vessels:

1. Responsibility for operation and routine care should be assigned to trained individuals.
2. A preventive maintenance program should include regular inspection of the chamber, door seals and all gauges and controls by qualified personnel.
3. The steam should be saturated and free from chemicals (e.g. corrosion inhibitors) that could contaminate the items being sterilized.
4. All materials to be autoclaved should be in containers that allow ready removal of air and permit good heat penetration; the chamber should be loosely packed so that steam will reach the load evenly.
5. For autoclaves without an interlocking safety device that prevents the door being opened when the chamber is pressurized, the main steam valve should be closed and the temperature allowed to fall below 80 °C before the door is opened.
6. Slow exhaust settings should be used when autoclaving liquids, as they may boil over when removed due to superheating.
7. Operators should wear suitable gloves and visors for protection when opening the autoclave, even when the temperature has fallen below 80 °C.
8. In any routine monitoring of autoclave performance, biological indicators or thermocouples should be placed at the centre of each load. Regular monitoring with thermocouples and recording devices in a “worst case” load is highly desirable to determine proper operating cycles.
9. The drain screen filter of the chamber (if available) should be removed and cleaned daily.
10. Care should be taken to ensure that the relief valves of pressure cooker autoclaves do not become blocked by paper, etc. in the load.

Homogenizers, Shakers, Blenders and Sonicators

Domestic (kitchen) homogenizers are not sealed and release aerosols. Only equipment designed for laboratory use should be used. Their construction minimizes or prevents such release. Stomachers, which are now available for use with large and small volumes, may also produce aerosols. Homogenizers used for Risk Group 3 microorganisms should always be loaded and reopened in biological safety cabinets. Sonicators may release aerosols. They should be operated in biological safety cabinets or covered with shields during use. The shields and outsides of sonicators should be decontaminated after use.

If you discover a fire, remain calm; do not shout "FIRE!"

1. Remove all individuals in immediate danger.
2. Close the door.
3. Report the fire immediately regardless of size.
 - a. Pull the nearest fire alarm box.
4. Clear the area of personnel. Take patients to designated refuge area. Direct others to evacuate the building.
5. If possible turn off gas, especially oxygen valves.

6. If possible, return flammable materials to approved storage cabinets.
7. Leave room or area, CLOSE THE DOOR.
8. Leave the building by the nearest accessible fire exit. Do not use elevators. Use stairs or exit through a fire door to an adjacent building.

Laboratory Design and Facilities

In designing a laboratory and assigning certain types of work to it, special attention should be paid to conditions that are known to pose safety problems. These include:

1. Formation of aerosols
2. Work with large volumes and/or high concentrations of microorganisms
3. Overcrowding and too much equipment
4. Infestation with rodents and arthropods
5. Unauthorized entrance
6. Workflow: use of specific samples and reagents.

Examples of laboratory designs for Biosafety Levels 1 and 2 are shown in Figures 2 and 3, respectively.

Design Features

1. Ample space must be provided for the safe conduct of laboratory work and for cleaning and maintenance.
2. Walls, ceilings and floors should be smooth, easy to clean, impermeable to liquids and resistant to the chemicals and disinfectants normally used in the laboratory. Floors should be slip-resistant.
3. Bench tops should be impervious to water and resistant to disinfectants, acids, alkalis, organic solvents and moderate heat.

RCPN

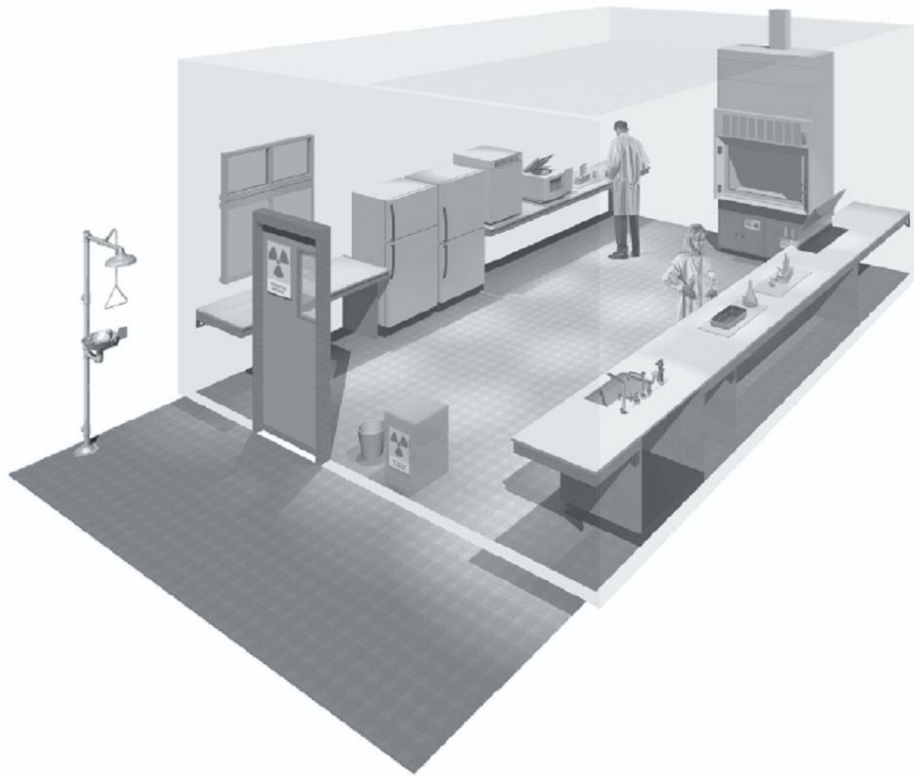

Figure6. A typical Biosafety Level 1 laboratory

- 4.** Illumination should be adequate for all activities. Undesirable reflections and glare should be avoided.
- 5.** Laboratory furniture should be sturdy. Open spaces between and under benches, cabinets and equipment should be accessible for cleaning.
- 6.** Storage space must be adequate to hold supplies for immediate use and thus prevent clutter on bench tops and in aisles. Additional long-term storage space, conveniently located outside the laboratory working areas, should also be provided.
- 7.** Space and facilities should be provided for the safe handling and storage of solvents, radioactive materials, and compressed and liquefied gases.
- 8.** Facilities for storing outer garments and personal items should be provided outside the laboratory working areas.
- 9.** Facilities for eating and drinking and for rest should be provided outside the laboratory working areas.
- 10.** Hand-washing basins, with running water if possible, should be provided in each laboratory room, preferably near the exit door.
- 11.** Doors should have vision panels, appropriate fire ratings, and preferably be selfclosing.
- 12.** At Biosafety Level 2, an autoclave or other means of decontamination should be available in appropriate proximity to the laboratory.
- 13.** Safety systems should cover fire, electrical emergencies, emergency shower and eyewash facilities.
- 14.** First-aid areas or rooms suitably equipped and readily accessible should be available
- 15.** In the planning of new facilities, consideration should be given to the provision of mechanical ventilation systems that provide an inward flow of air without recirculation. If there is no

mechanical ventilation, windows should be able to be opened and should be fitted with arthropod-proof screens.

16. A dependable supply of good quality water is essential. There should be no crossconnections between sources of laboratory and drinking-water supplies. An antbackflow device should be fitted to protect the public water system.

17. There should be a reliable and adequate electricity supply and emergency lighting to permit safe exit. A stand-by generator is desirable for the support of essential equipment, such as incubators, biological safety cabinets, freezers, etc., and for the ventilation of animal cages.

18. There should be a reliable and adequate supply of gas. Good maintenance of the installation is mandatory.

19. Laboratories and animal houses are occasionally the targets of vandals. Physical and fire security must be considered. Strong doors, screened windows and restricted issue of keys are compulsory. Other measures should be considered and applied, as appropriate, to augment security.

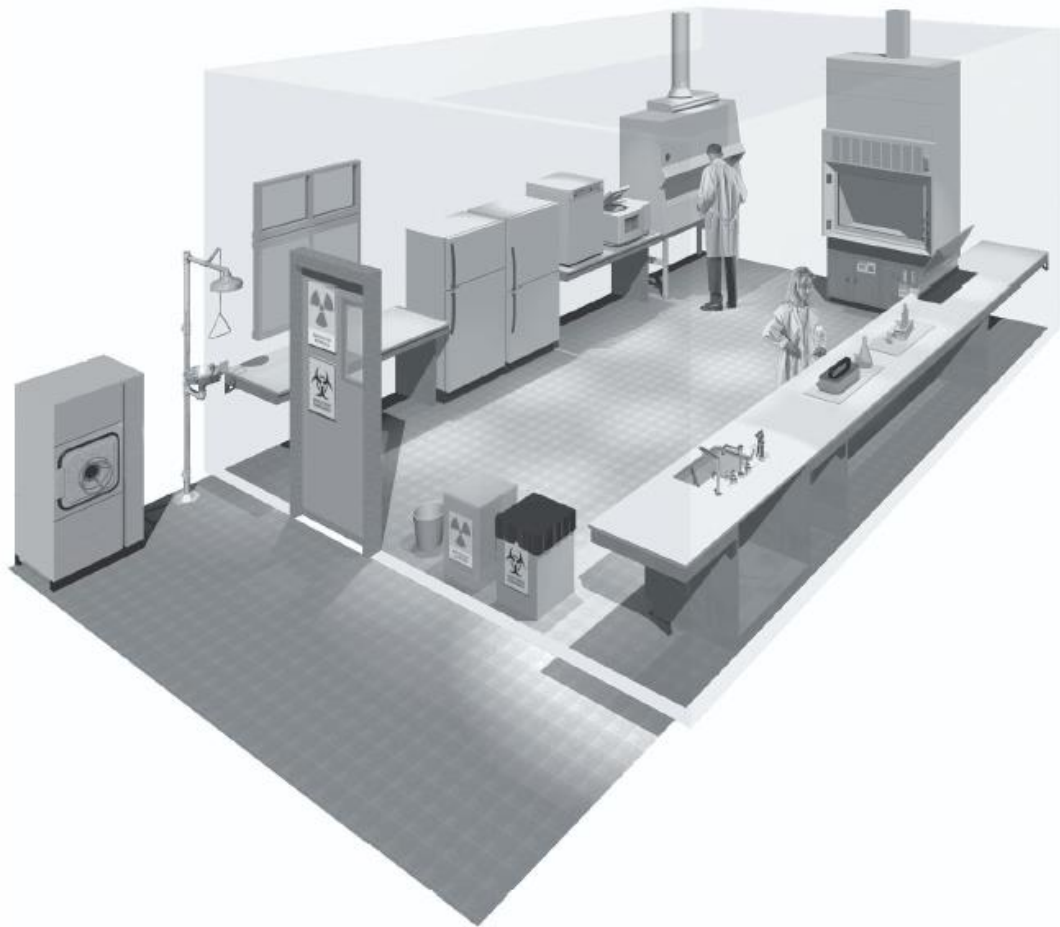

Figure7. A typical Biosafety Level 2 laboratory

Procedures likely to generate aerosols are performed within a biological safety cabinet. Doors are kept closed and are posted with appropriate hazard signs. Potentially contaminated wastes are separated from the general waste stream.

Lab Safety Awareness for Non-Lab Staff

General Practices

- Always assume everything you touch is contaminated.
- Always wear gloves if you are going to touch lab equipment. Remove gloves before leaving the lab!
- Don't work in labs if lab staff is working.
- Never touch or move lab equipment yourself - always ask the lab staff to do it.
- Never touch a "sharp".
- Never take anything out of the lab because *"it's really cool"*.
- Don't remove empty chemical containers unless they're marked as "triple rinsed".
- Always check countertops & cabinets before work
- Lab clean-outs are full of unknowns: remember to look inside drawers & cabinets before moving them.

Personal Protective Equipment and Clothing

Personal protective equipment and clothing may act as a barrier to minimize the risk of exposure to aerosols, splashes and accidental inoculation. The clothing and equipment selected is dependent on the nature of the work performed. Protective clothing should be worn when working in the laboratory. Before leaving the laboratory, protective clothing should be removed, and hands should be washed.

Laboratory Coats, Gowns, Coveralls, Aprons

Laboratory coats should preferably be fully buttoned. However, long-sleeved, back-opening gowns or coveralls give better protection than laboratory coats and are preferred in microbiology laboratories and when working at the biological safety cabinet. Aprons may be worn over laboratory coats or gowns where necessary to give further protection against spillage of chemicals or biological materials such as blood or culture fluids. Laundering services should be provided at/near the facility. Laboratory coats, gowns, coveralls, or aprons should not be worn outside the laboratory areas.

Goggles, Safety Spectacles, Face Shields

The choice of equipment to protect the eyes and face from splashes and impacting objects will depend on the activity performed. Prescription or plain eye glasses can be manufactured with special frames that allow lenses to be placed in frame from the front, using shatterproof material either curved or fitted with side shields (safety glasses). Safety spectacles do not

provide for adequate splash protection even when side shields are worn with them. Goggles for splash and impact protection should be worn over normal prescription eye glasses and contact lenses (which do not provide protection against biological or chemical hazards). Face shields are made of shatterproof plastic, fit over the face and are held in place by head straps or caps. Goggles, safety spectacles, or face shields should not be worn outside the laboratory areas.

Respirators

Respiratory protection may be used when carrying out high-hazard procedures (e.g. cleaning up a spill of infectious material). The choice of respirator will depend on the type of hazard(s). Respirators are available with interchangeable filters for protection against gases, vapors, particulates and microorganisms. It is imperative that the filter is fitted in the correct type of respirator. To achieve optimal protection, respirators should be individually fitted to the operator's face and tested. Fully self-contained respirators with an integral air supply provide full protection. Advice should be sought from a suitably qualified person, e.g. an occupational hygienist, for selection of the correct respirator. Surgical type masks are designed solely for patient protection and do not provide respiratory protection to workers. Some single-use disposable respirators (ISO 13.340.30) have been designed for protection against exposures to biological agents. Respirators should not be worn outside the laboratory areas.

Gloves

Contamination of hands may occur when laboratory procedures are performed. Hands are also vulnerable to "sharps" injuries. Disposable microbiologically approved latex, vinyl or nitrile surgical-type gloves are used widely for general laboratory work, and for handling infectious agents and blood and body fluids. Reusable gloves may also be used but attention must be given to their correct washing, removal, cleaning and disinfection. Gloves should be removed and hands thoroughly washed after handling infectious materials, working in a biological safety cabinet and before leaving the laboratory. Used disposable gloves should be discarded with infected laboratory wastes. Allergic reactions such as dermatitis and immediate hypersensitivity have been reported in laboratory and other workers wearing latex gloves, particularly those with powder. Alternatives to powdered latex gloves should be available. Stainless steel mesh gloves should be worn when there is a potential exposure to sharp instruments e.g. during postmortem examinations. Such gloves protect against slicing motion but do not protect against puncture injury. Gloves should not be worn outside the laboratory areas.

Putting On PPE

- Essential to first assess your surroundings
- Type of PPE varies with situation
- Wash hands first – then put on Gown
- Put on mask or N95 Respirator
- Put on Goggles or Face Shield

- Finally put on Gloves

Taking Off PPE

- Gloves off first
- Remove Face Shield or Goggles
- Remove Gown – wash hands
- Remove surgical mask or Respirator
- Wash hands – again!

Sharps Safety

Needles, syringes and other "sharps" (scalpels, razor blades, slides and cover slips, microtome blades) are used in many labs. They are used with biological, chemical and radiological hazardous materials. It is important to use good lab work practices when handling this equipment and to dispose of them properly.

Do not recap needles. If recapping is required for the procedure being done, use a mechanical device such as tongs or forceps, a recapping device or one-hand scoop method to recap needle. Never recap needles using one hand to hold the cap and the other to hold the needle! Do not recap needles prior to disposal. They must be disposed of directly into an appropriate sharps container.

How can you protect yourself from sharps injuries?

- Avoid the use of needles if safe and effective alternatives are available.
- Select, evaluate and use devices with safety features that reduce the risk of needlestick injury.
- Do not recap needles.
- Plan for safe handling and disposal of needles before using them.
- Locate sharps containers as close as possible to the area where they are used.
- Promptly dispose of used sharps in appropriate sharps disposal container.
- Put uncapped needles in rigid tray or insert needle into cork ring or styrofoam block if reusing the device during procedure.
- Report all needlestick and sharps-related injuries promptly to ensure that you receive appropriate follow-up care.
- Substitute plasticware for glass whenever possible.
- Follow safety guidelines for all sharps hazards (razor blades, scalpels, slides, microtome blades).
- Participate in training.

Always dispose of needles and other regulated sharps in a rigid, puncture resistant container immediately after use. Additional information on proper disposal and definitions of a "regulated sharp" can be found on the Sharps Waste page.

Non-regulated sharps (not contaminated with infectious material; excludes needles/syringes) and broken glassware must be handled safely and disposed of in containers that will prevent

injuries to anyone else handling the container. Heavy duty plastic containers or cardboard boxes labeled "sharp" or "broken glass" and securely taped closed are acceptable.

Signs and Labels

Signs Required in Every Lab

The Laboratory Emergency Information Template for your lab door. It includes space for emergency contact information and hazard warnings.

The Laboratory Emergency Plan Template includes evacuation and emergency response information.

No food or drink sign



Biosafety Door Sign:



BIOSAFETY LEVEL 1
LOW CONTAINMENT / LOW RISK

HAZARD(S) PRESENT: _____

ACCESS: **AUTHORIZED PERSONNEL ONLY – STAFF, STUDENTS, & FACULTY**

PRECAUTIONS: **STANDARD MICROBIOLOGICAL PRACTICES; LAB COATS AND GLOVES SHOULD BE WORN DURING ALL PROCEDURES WITH BIOHAZARDOUS MATERIALS. LAB COATS AND GLOVES ARE REMOVED BEFORE LEAVING ROOM**

RESPONSIBLE INVESTIGATOR: _____

DAYTIME CONTACT: _____

EMERGENCY CONTACT: _____



BIOSAFETY LEVEL 2
MODERATE CONTAINMENT / MODERATE RISK

ACCESS: **AUTHORIZED FACULTY, STAFF AND ESSENTIAL SUPPORT PERSONNEL**

PRECAUTIONS: **STANDARD MICROBIOLOGICAL PRACTICES; LAB COATS AND GLOVES MUST BE WORN DURING ALL PROCEDURES. LAB COATS AND GLOVES ARE REMOVED BEFORE LEAVING ROOM**

RESPONSIBLE INVESTIGATOR: _____

EXTENSION: _____ AFTER HOURS CONTACT: _____



BIOSAFETY LEVEL 3
HIGH CONTAINMENT / HIGH RISK
EMERGENCY RESPONDERS -
SCBA MUST BE WORN FOR ENTRY!

ACCESS: **ALL UNAUTHORIZED PERSONS KEEP OUT!**
ACCESS ALLOWED FOR PRINCIPAL INVESTIGATOR AND APPROVED STAFF.

PRECAUTIONS: **STANDARD MICROBIOLOGICAL PRACTICES; SPECIAL CLOTHING MUST BE WORN DURING ALL PROCEDURES, REMOVE SPECIAL CLOTHING AND OUTER GLOVES BEFORE LEAVING THE ROOM.**

PRINCIPAL INVESTIGATOR: _____

EXTENSION: _____ AFTER HOURS CONTACT: _____

Biohazard Signs

Use this for equipment that contains biohazardous material or may be contaminated with biohazardous material:



Use this sign on refrigerators containing biohazardous materials, including blood samples:



Chemical Signs

Use this sign on refrigerators that are not "laboratory safe" for flammable liquid storage:



Use this sign on refrigerators containing chemicals:



Use this sign on refrigerators that are used for food only:

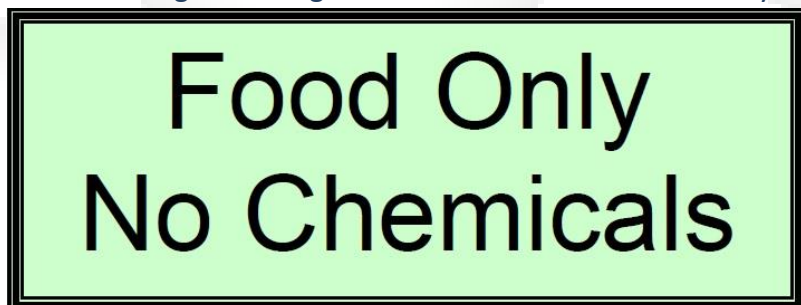

Use these labels on containers of 70% Ethanol:

70% Ethanol



DANGER

Highly flammable liquid and vapor. Causes skin irritation. Causes serious eye irritation. Keep away from heat/sparks/open flames/hot surfaces.

IF IN EYES: Rinse cautiously with water for several minutes. Remove contact lenses, if present and easy to do. Continue rinsing.

Read SDS for more information.

Use these

labels on

containers of Dichloromethane/Methylene Chloride:

**___% Dichloromethane
(DCM)**



WARNING

May be harmful if swallowed or in contact with skin. Causes serious eye irritation. Suspected of causing cancer. May cause damage to organs (liver, blood, CNS).

IF IN EYES or SKIN: Rinse cautiously with water for 15 minutes.

Dispose as hazardous waste.

Read SDS for more information.

Use these labels on containers of Ethanol:

_____ % **Ethanol**



DANGER

Highly flammable liquid and vapor. Keep container tightly closed. Keep away from heat/sparks/open flames/hot surfaces. Wear gloves and eye protection.

IF IN EYES: Rinse cautiously with water for 15 minutes.

Read SDS for more information.

Use these labels on containers of Ethyl Acetate:

_____ % **Ethyl Acetate**
(EA)



DANGER

Highly flammable liquid and vapor. Causes serious eye irritation. May cause drowsiness or dizziness. Keep container tightly closed. Keep away from heat/sparks/open flames/hot surfaces. Wear gloves and eye protection.

IF IN EYES: Rinse cautiously with water for 15 minutes.

Dispose as hazardous waste.

Read SDS for more information.

Use these labels on containers of Hydrochloric Acid:

_____ % **Hydrochloric Acid**
(HCl)



DANGER

Causes severe skin burns & eye damage. May cause respiratory irritation. Wear gloves and eye protection.

IF IN EYES or SKIN: Rinse cautiously with water for 15 minutes.

Dispose as hazardous waste.

Read SDS for more information.

Use these labels on containers of Methanol:

_____ % **Methanol**
(MeOH)



DANGER

Highly flammable liquid & vapor. Toxic if swallowed, in contact with skin or if inhaled. Causes damage to organs.

IF IN EYES or SKIN: Rinse cautiously with water for 15 minutes.

Dispose as hazardous waste.

Read SDS for more information.

Spill Clean-Up Procedure

In the event of a spill of infectious or potentially infectious material, the following spill clean-up procedure should be used.

1. Wear gloves and protective clothing, including face and eye protection if indicated.
2. Cover the spill with cloth or paper towels to contain it.
3. Pour an appropriate disinfectant over the paper towels and the immediately surrounding area (generally, 5% bleach solutions are appropriate; but for spills on aircraft, quaternary ammonium disinfectants should be used).
4. Apply disinfectant concentrically beginning at the outer margin of the spill area, working toward the centre.
5. After the appropriate amount of time (e.g. 30 min), clear away the materials. If there is broken glass or other sharps involved, use a dustpan or a piece of stiff cardboard to collect the material and deposit it into a puncture-resistant container for disposal.
6. Clean and disinfect the area of the spillage (if necessary, repeat steps 2–5).
7. Dispose of contaminated materials into a leakproof, puncture-resistant waste disposal container.
8. After successful disinfection, inform the competent authority that the site has now been decontaminated.

Transport of Infectious Substances

Transport of infectious and potentially infectious materials is subject to strict national and international regulations. These regulations describe the proper use of packaging materials, as well as other shipping requirements.

Laboratory personnel must ship infectious substances according to applicable transport regulations. Compliance with the rules will:

1. Reduce the likelihood that packages will be damaged and leak, and thereby
2. Reduce the exposures resulting in possible infections
3. Improve the efficiency of package delivery.

The Basic Triple Packaging System

The triple packaging system, the choice for the transport of infectious and potentially infectious substances. This packaging system consists of three layers: the primary receptacle, the secondary packaging and the outer packaging.

The primary receptacle containing the specimen must be watertight, leakproof and appropriately labelled as to content. The primary receptacle is wrapped in enough absorbent material to absorb all fluid in case of breakage or leakage.

A second watertight, leakproof packaging is used to enclose and protect the primary receptacle(s). Several wrapped primary receptacles may be placed in a single secondary packaging. Volume and/or weight limits for packaged infectious substances are included in certain regulatory texts.

The third layer protects the secondary packaging from physical damage while in transit. Specimen data forms, letters and other types of information that identify or describe the specimen and identify the shipper and receiver, and any other documentation required must also be provided according to latest regulations.

Packing and labelling of Category a infectious substances

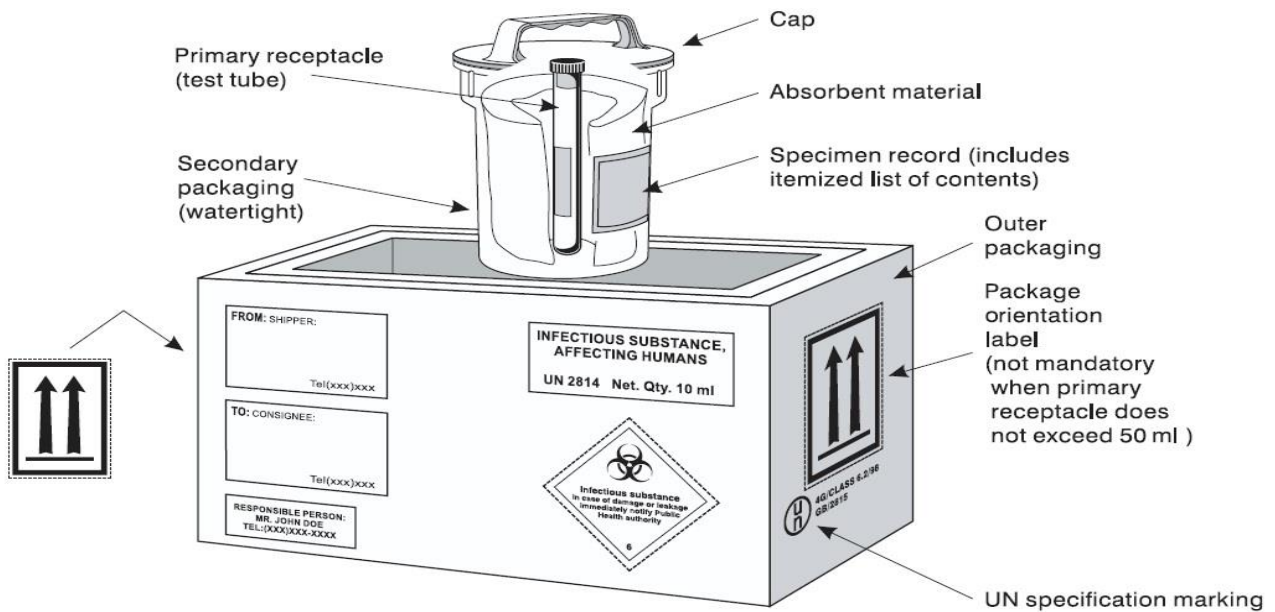

Packing and labelling of Category B infectious substances

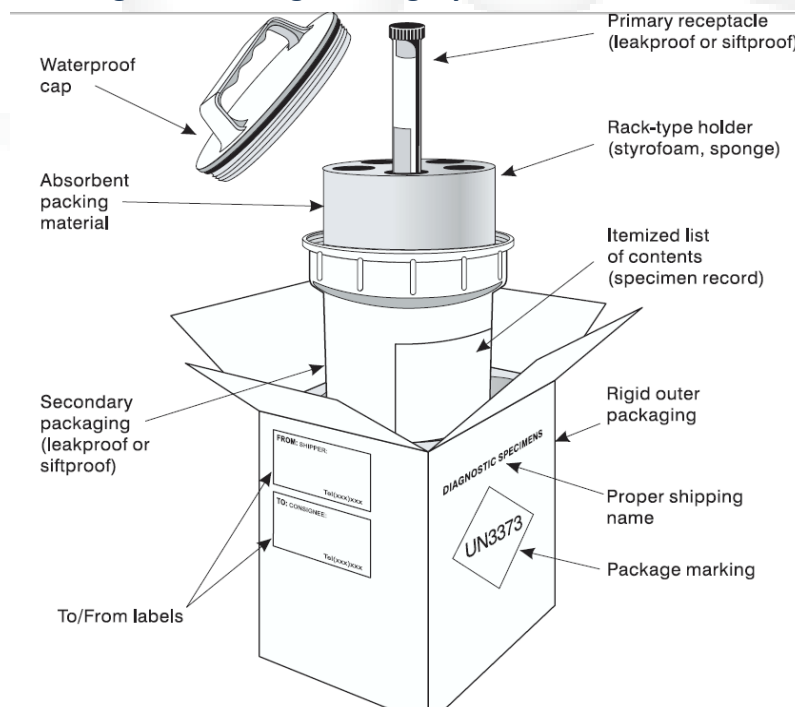

Figure 8. Examples of triple packaging systems.

Use of Pipettes and Pipetting Aids

1. A pipetting aid must always be used. Pipetting by mouth must be prohibited.
2. All pipettes should have cotton plugs to reduce contamination of pipetting devices.
3. Air should never be blown through a liquid containing infectious agent.
4. Infectious materials should not be mixed by alternate suction and expulsion through a pipette.
5. Liquids should not be forcibly expelled from pipettes.
6. Mark-to-mark pipettes are preferable to other types as they do not require expulsion of the last drop.
7. Contaminated pipettes should be completely submerged in a suitable disinfectant contained in an unbreakable container. They should be left in the disinfectant for the appropriate length of time before disposal.
8. A discard container for pipettes should be placed within the biological safety cabinet, not outside it.
9. Syringes fitted with hypodermic needles must not be used for pipetting.
10. Devices for opening septum-capped bottles that allow pipettes to be used and avoid the use of hypodermic needles and syringes should be used.
11. To avoid dispersion of infectious material dropped from a pipette, an absorbent material should be placed on the working surface; this should be disposed of as infectious waste after use.

Working Alone in Research Labs

Working alone, especially after hours, can be unsafe and should be avoided whenever possible. When it cannot be avoided, procedures to protect lab workers in the event of an emergency situation must be used. The Principal Investigator (PI) has the responsibility to ensure the safety of all lab workers in their laboratory, and after conducting a hazard review, can approve laboratory staff to work alone. Guidance is provided to develop a lab specific safety protocol for working alone. This policy applies to all work with hazardous materials (chemical, biological or radiological material) or hazardous equipment in research laboratories at RCPN.

The requirements are:

High School Students: Never permitted to work alone in a research lab, even with non-hazardous materials. They must always have a mentor/supervisor present. Review the Minors in Research Labs policy for additional information, including the requirements for "Qualified Supervisor".

Undergraduate Students: Never permitted to work alone with hazardous materials or equipment. Someone else required safety training must be in the lab or adjacent to the lab and be able to check on their safety.

Graduate Students, Postdoctoral Fellows, Research Scientists, Technicians and Principal Investigators: These are considered full time laboratory workers, and laboratory training is integral to their professional training. They are permitted to work alone in a research laboratory after approval by the PI and following the lab's safety protocol for working alone.

Clinical Students, including Medical Students, Residents and Clinical Fellows:

Since their laboratory training is only a portion of their professional training and works intermittently in a research lab and have minimal laboratory experience, are not permitted to work alone in a research lab with hazardous materials. They must use the "buddy system". Lab workers in this category, who have previous laboratory experience or where the non-clinical education is the primary laboratory training and experience, are permitted to work alone in a research laboratory after approval by the PI and following the lab's safety protocol for working alone.

RCPN

References

1. Organization, W.H., Laboratory biosafety manual. 2004: World Health Organization.
2. Arnett, E., Prudent Practices in the Laboratory: Handling and Disposal of Chemicals. 1995, National Academy Press, Washington, DC.
3. PRECAUTIONS, L.I.G.S., L.I.S. PRECAUTIONS, and B.L. LEVEL III, Johns Hopkins Medical Laboratories Safety Manual. Director, 2009.
4. Canadian Biosafety Standard (CBS) Second Edition.
<http://canadianbiosafetystandards.collaboration.gc.ca/>
5. Stony Brook university, Environmental health and safety,
<http://www.stonybrook.edu/ehs/lab/lab-safety-a-to-z.shtml>
6. Laboratory safety review, Blood-Borne Pathogens and Safety Measures for Laboratory Practitioners Janice M. Conway-Klaassen, PhD, MT(ASCP)SM Director, Medical Laboratory Science Program University of Minnesota
7. Laboratory safety manual, TML\MSH Microbiology Department Policy & Procedure Manual. Microbiology at Mount Sinai Hospital, Toronto, Canada, 2001

RCPN

Document ID: RCPN 53

Document name	Safety guidelines in RCPN
Document arrangement	Mohanna Osali
Date	5/26/2018
Full file name	Safety guidelines in RCPN
Document Description	The main objective of this training manual is to provide a brief overview and insight upon the lab safety requirements in order to prevent accidents, injuries, and illness during the job/experiment.
Author / translator	Asal golchin